

South Dakota Department of Education  
Office of Curriculum, Technology, and Assessment  
Technology Plan Submission

**Parkston School District 33-3  
102 C South Chapman Drive  
Parkston, SD 57366**

Submission Date to SDDOE  
**January 31, 2011**

Approved Plan will be effective from  
**July 1, 2011 – July 1, 2014**

Technology Plan Submitted by:

Tony Kinneberg  
Parkston Technology Coordinator

[Tony.Kinneberg@k12.sd.us](mailto:Tony.Kinneberg@k12.sd.us)  
Phone Number: 605-928-3368  
Fax Number: 605-928-4032

# Parkston Technology Plan

2011-2014

Parkston School District 33-3  
Parkston, South Dakota

# **Table of Contents**

List of Technology Committee Member

Vision Statement

Needs Assessment

Consolidated Application

Three-Year Goals and Objectives

Inventories (On-Line State Survey Site)

Policies

Adult Literacy

Evaluation

Appendix

# **List of Technology Committee Members**

## Technology Committee

Shayne McIntosh	Superintendent
Joe Kollmann, Rob Monson	Principals
Justin Thury	Network Administrator
Tony Kinneberg	Technology Coordinator
Paula Waltman, Nancy Lorenz	Elementary Teachers
Patricia Freeland, Kim McCann	Jr./Sr. High Teachers
Two Students (Rotating Basis)	Student Council
Two Parents (Rotating Basis)	Parents/Community
School Board Member (Rotating Basis)	School Board

The Technology Committee will meet the first Mondays in the Month of September, February, May.

# **Vision Statement**

## Vision Statement

The Technology Plan of the Parkston School District 33-3 is always changing and our Vision Statement reflects the constant need to review, adapt, and revamp to better meet the educational needs of our students. Our Vision is reflective of our students' needs, staff development concerns, and the training and encouragement of our community.

First, We need to address the needs of our students. We must continue to offer a curriculum that is challenging and well rounded to ensure our students have the marketable skills needed for a global marketing community. We must continue to offer courses that will ensure our students are proficient in computer related skills and meet the proficiency standards set by the "No Child Left Behind" legislation. We will continue to use distance-learning courses to supplement the curriculum that cannot be taught in house. The use of on-line and the Dakota Digital Network will play a vital role in securing the needed distance learning courses.

Second, The district's vision is to address the ever-changing needs of our students in the new technological world. We must ensure that our students have the necessary skills in the 21<sup>st</sup> century. These skills include critical and creative thinking, problem solving skills, information and computer skills, research and writing skills, interpersonal and self-directed skills, and technology literacy skills.

Third, The district must continue to provide professional development for all our staff that includes teachers, aids, administration, maintenance staff, kitchen staff and secretarial staff. We will continue to build on the computer skills necessary to enhance the technology use in the classroom. The training will come through grants set aside for professional development, area supportive consortiums like DIAL, ESA, and local mentoring programs within the school district. Distance learning will provide access for certifications, credit options, and mentoring programs from across the state. Staff must be trained to evaluate data and map out course work that provides better instructional strategies. Technology will shift from skills related to database driven results. The staff will evaluate ways to incorporate technology to continually improve their curriculum and ensure their technology skills are advancing along with the new technologies available.

Fourth, We must continue to embrace our community and aid in whatever is necessary to help our community use the existing technology. We will continue to provide opportunities for training, disseminating technology information, and provide use to distance learning equipment and courses that are made available.

Our Vision is a reflection of how vital the relationship is between community and school for a successful academic experience for our students. We have embraced the new opportunity of creating a media channel so our community can see firsthand how technology can enhance school/community communication. Technology will continue to play a vital role in the success of that relationship and help Parkston become a global community.

## MISSION STATEMENT – DISTRICT #33-3

Preface: To empower all to succeed in a 21<sup>st</sup> Century changing world.

Our commission to students is to develop the intellectual, physical, emotional health, the ethical values, vocational competence, the appreciation for family and civic roles, and appreciation of the democratic processes to the best of their capabilities. We are committed to develop a feeling of positive worth in young people, which will allow them to maintain a zeal for continuous learning and self-improvement. Our aim being to provide quality education and recognizing a quality staff is the key to quality education. We are dedicated to the development of skills and full human potential of all staff members. We want the home and the schools to work closely together to strengthen the educational process.

### PHILOSOPHY OF EDUCATION

The Board of Education of the Parkston School District #33-3 believes that each individual should be accepted into the educational program as he/she is, that he/she shall be provided with a stimulating environment and opportunities for learning and to become life-long learners.

#### WE BELIEVE

- All students can learn, achieve and succeed when given the correct level and time for learning
- Every student has the right and responsibility to learn basic and life skills
- Education, being a valuable asset, is a responsibility shared by the student, school, home and community
- Parental and community participation is vital to student success
- A quality school system enhances the quality of the community
- That successful learning occurs when adults, peers and students all have high expectations for success
- Changes can create the opportunity to improve

We believe that we should focus and organize all of the school's programs and instructional efforts around clearly defined expectations that we want students to demonstrate when they leave school.

#### WE BELIEVE STUDENTS SHOULD BE ABLE TO:

- Be proficient in listening, speaking, reading, writing, mathematics, and the use of technology.
- Demonstrate knowledge of the arts and sciences.
- Demonstrate a healthy self-esteem.
- Select and use thinking skills individually and in groups to solve problems and to make decisions.
- Find, evaluate and use information.
- Be self-directed learning who are adaptable to change.
- Demonstrate a positive work ethic.
- Recognize and care for their environment, their heritage and the rights, opinions and property of others.
- Recognize the importance that technology will play in the 21<sup>st</sup> Century.

As a result of these beliefs, students should be able to apply what they learn, effectively make decisions with that knowledge, and be responsible for their actions.



# **Needs Assessment**

# Needs Assessment

The staff at Parkston School District 33-3 continues to use technology on a daily basis. The staff will use email, web page and voicemail to communicate information to parents, students, and other facility.

Our staff has access to distance learning opportunities that include mentoring classes, workshops and conferences provided within our consortium. The staff will use the Dakota Digital Network to find additional learning opportunities for their students to help integrate technology into a specific content area. They incorporate WebCT to help manage coursework materials to be accessed by the students along with educational streaming video that is offered through the Digital Curriculum or United Streaming web sites. All staff has access to desktop computers, laptop computers, LCD projectors and digital input devices like cameras, and scanners.

Our school district has incorporated a web based student data system that allows students, and parents to follow the student's educational progress through daily monitoring of grades, discipline, and daily attendance. The student data system also allows students to track their coursework to ensure they are meeting state and school district requirements for graduation. Students from the senior class create digital portfolios that includes gathering of materials like writing examples, projects, letters of recommendations, references, resumes, list of activities and awards, application letters, employment experience, volunteer work, and transcripts. These portfolios are then burned to a cd so the student will have access to the information for future use.

Our community has access to distant learning opportunities like training for emergency personnel, certification for childcare workers, and college level coursework. The school district offers community computer classes in areas like email, Internet uses, scanners, digital cameras and various types of software.

On a yearly basis we evaluate the technology goals and infrastructure to see where the needs are for the school district. We look at areas of professional development for staff in areas of technology integration, curriculum mapping using data collected through various testing agents, and instructional strategies to help staff improve in areas of instructional practices and technology integration.

The infrastructure is a constant upgrade or replacement of hardware and software. The technology committee gathers data from parents, students, staff and community to see what area of needs are being met and what needs are not being met from a stand point of technology within the Parkston community. Surveys address questions like: How well were you prepared for using technology at the post-secondary level? Are there areas that you felt you could have had more instruction in to be better prepared for college? What type of distant learning opportunities would be helpful for community members? What type of classes would community members like to see taught? How can the school assist

businesses in the community? (An example might be the use of equipment for a presentation that a business is doing for training.)

The school district has ventured into a new area of technology with a media production class that will incorporate scripting, editing, producing, filming and then uploading their product to our local cable company. This project came about as a survey and a needs assessment from our student body.

In conclusion, the data is used to formulate what our needs are for professional development, student achievement, infrastructure, and community support. We will continue to address areas of distant learning opportunities for all staff and build on the successful mentoring programs already in place. Our goals reflect more training in database analysis and curriculum mapping along with continual training in content specific areas like reading and math. We will continue to use support groups like DIAL or our ESA to formulate strategies in these specific areas. Student achievement will address curriculum needs. Our goals will focus on distance learning, coursework management, digital portfolios and advanced computer opportunities. We will handle our infrastructure issues by utilizing bar coding to ensure all equipment and software is accounted for. The district will update all networking infrastructure that includes servers, switches and access points. The school has purchased smart boards and LCD projectors for the Junior and Senior High classrooms and the goal for the next three years is to extend this technology to the elementary classrooms. The technology committee will be a valuable resource for recommendations of all technology-based purchases. Finally, we will continue to address the needs of the community and our goals will be to continue community classes, distance learning and answer questions that relate to technology uses.

# **Consolidated Application**

**The goal of the district is to keep the staff and students up to date with the latest trends in educational technology and provide the necessary support to achieve such.**

Goal:1 Student Learning: the district will provide every child an opportunity to achieve, to provide a learning environment to be proficient in the basic skills of life that are of reading, writing, verbal communication, numerical understanding, and technology skills for the 21<sup>st</sup> Century.

Goal 2: Effective instructional strategies: to encourage student creativity that allows for the individual to develop skills, interests, and the necessary tools that are the basics for the fundamental skills of the 21<sup>st</sup> Century.

Goal 3: Curriculum standards: To provide a curriculum that is robust and offers the highest standards for meeting the needs of the student to reach their fullest potential and equip them to be able to continue on to a post-secondary education.

Goal 4: School Environment: to create a sense of self worth by building habits of healthy living that includes education, social skills, technology skills, vocational skills to better prepare the individual for the 21<sup>st</sup> Century.

These goals tie into the school district as a one-to-one laptop initiative school since 2007. The district has determined that in order to prepare our students for the 21<sup>st</sup> Century that our students must be able to develop appropriate technology skills that will be valuable in a global economy. The process of training staff and students in these technology skills is a vital goal for success in both education and career developing skills for future employment.

The district has purchased tablets/laptops that are used by students in grade nine through twelve. The staff is being trained on how to incorporate the new technology into the classroom. This technology has included smart boards and LCD projectors along with many online textbooks with helpful presentational materials. The students are using the new technology for

exploration of course material and learning new ways of communication that will be beneficial in either furthering their education or entering the job market.

The district has continued to upgrade its network infrastructure and will continue to strive to better educate its students so that they can be successful in the 21<sup>st</sup> Century. We are living in a society that technology will be the basis of our educational system as well as our economic system. The goal for our district will be to embrace the new technology changes and ensure that every student that graduates will have a competitive edge in our vast global economy.

The district will continue to try and create the best learning environment for each individual student. The district takes a proactive stand on creating this environment through teaching students about bullying, sexting, ethical use of social networks and emailing systems.

# **Three Year Goals**

**Three Year Goal(s) – Improving Student Academic Achievement**

**Goal:** To provide each child an opportunity to achieve proficiency in the basic skills of reading, writing, oral communications, numbers, and the fundamental skills of learning for the 21<sup>st</sup> Century.

**Goals need to tie to State Standards. Does your goal tie to State Standards?**  YES  NO

Objective	Activity	Timeline	Quantity	Projected Cost	Category and Source of Funding	Evaluation
Provide each child an opportunity to achieve proficiency in the fundamental skill of learning by providing a strong Technology component.	Students in grades 1-8 will engage in instructional time to improve keyboarding skills	ongoing	300 Students	N/A	General Fund	80% of all students will properly key 25 words per minute by the end of 6th grade and 40 words per minute by the end of 8 <sup>th</sup> grade
	Students in grades K-12 will receive instruction in operation of technology according to the grade level standards	ongoing	580 Students	N/A	General Fund	80% of all K-12 students will demonstrate skills in the operation of technology
	Teachers and students in grades 7-12 will engage in mobile technology in the learning environment	ongoing	250 Students	N/A	General Fund	100% of all 7-12 students will utilize mobile technology in the learning environment
	K-12 teachers will expose students to distance and virtual learning	ongoing	580 Students	N/A	General Title I	K-12 students will access, evaluate, and use informational resources to develop skills for 21 <sup>st</sup> Century Skills
Improve student and Teacher communications	Grade 7-12 will learn to use email and other	ongoing	250 Students			Use of email, Quia, webct, use in ethical manner. The student is evaluated on



	communication tools to communicate with staff show understanding of proper use of technology					using the tools in classroom and demonstrating on how to correctly use the tools. Observation by staff. Survey
	Provide professional development for technology integration training using of Quia, virtual labs, educational software, WebCt, web page design, RSS feeds, distance/virtual learning, and webquests.	ongoing	NA	N/A	General Title I	Observation will be used to evaluate instruction
	Teachers will utilize the South Dakota State technology standards at their grade level	ongoing	All Students	N/A	General Fund	K-12 teachers will document use of technology standards in coursework
Equip teachers with data for assessment to drive instruction.	All teachers will use technology for assessment	ongoing	All students	N/A	General Fund	Increase student achievement.

**Three Year Goal(s) - Professional Development.**

**Goal:** To encourage teacher creativity that allows for the development of learning styles, and interests of the child.

**Goals need to tie to State Standards. Does your goal tie to State Standards?** YES NO

Objective	Activity	Timeline	Projected Cost	Quantity If Applicable	Category and Source of Funding	Evaluation
Provide	Provide	2011-2014	NA	50 Staff	General	Workshop attendance

teachers and paraprofessionals with professional development opportunities to improve instruction.	opportunities for technology staff to further knowledge and skills.			Members		as provided by state and other sources
All teaching staff will use technology to enhance instruction.	All teachers will expose students to distance and virtual learning.	2011-2014	N/A	All staff	General Fund Title I	K-12 students will access, evaluate, and use information resources in an ethical manner
	All teachers and paraprofessionals will receive professional development pertaining to technology and/or tech integration.	2011-2014	N/A	All Staff	General Fund	100% workshop and or In-service attendance
Provide training and assistance to using various software tools to increase technology integration into the classroom	Provide professional development for technology integration training using Quia, virtual labs, educational software, WebCt, web page design, RSS feeds, distance/virtual learning, and web quests.	2011-2014	\$400 to purchase Quia  \$700 for Renaissance Learning	10 Staff for purchase Quia  Title Staff and Students	Title I General Fund	Observation will be used to evaluate instruction and testing results for students.
	Each 7 – 8 grade student will have access to	2011-2014	N/A Uses Existing Equipment	Middle School Staff	General Fund Title I	Middle School teachers will incorporate technology standards

	tablet/laptop assigned to them for use in classes.					in coursework
All teachers and administrators will create plans to increase self efficacy.	All teachers will identify one goal and indicators related to technology skills in their professional growth plan.	2011-2014	N/A	All Staff	General Fund	Professional development plans

**Three Year Goal(s) - Improve Integration of Technology with Curricula and Instruction.**

**Goal:** To provide a curriculum that creates skills necessary for the 21<sup>st</sup> Century and also meeting the requirements set forth by the state.

**Goals need to tie to State Standards. Does your goal tie to State Standards?** YES NO

Objective	Activity	Timeline	Projected Cost	Category and Source of Funding	Evaluation
All K-12 administrators and teachers will understand and use the SD technology standards.	Teachers will become familiar with the South Dakota state technology standards at their grade level.	ongoing	N/A		teachers will document use of technology standards in coursework Lesson plans, observation
Use of technology software for presentation	Teachers will use presentation software that come with white board technology	Ongoing	NA	General Funds	Teacher will use notebook software to enhance instructional delivery
Advance placement coursework for students grades 11 & 12	Students register for online AP courses form regional colleges	Ongoing	N/A	Student/Parent and school district responsibility	HS Transcripts

**Three Year Goal(s) - Improvement of Infrastructure and Technology.**

**Goal:** To continue to improve the network infrastructure of the district as well as replacement of tools that is necessary to build the skills of 21<sup>st</sup> Century for students and staff.

**Goals need to tie to State Standards. Does your goal tie to State Standards?**  YES  NO

Objective	Activity	Timeline	Projected Cost	Quantity If Applicable	Category and Source of Funding	Evaluation
All staff and students will benefit from a technology rich learning and teaching environment.	Teachers and students in grades 7-12 will engage in mobile technology in the learning environment.	2011-2014	N/A	30 Staff 245 Students	General Fund Title I	100% of all 7-12 students will utilize mobile technology in the learning environment
	Acquire and/or upgrade hardware and software as needed.	2011-2014	\$25,000 / 3 year period	NA	Capital Outlay	Year end evaluation. Observation, and assessments of students
	Maintain an efficient, connective, reliable, and secure system.	2011-2014	\$15,000 over 3 year period		Capital Outlay	Connectivity maintained throughout the year
	Sound System in classrooms	2011-2014	\$850	2/Year	Capital Outlay	Purchase, Observation, student survey
	Purchase Student Laptops	2011-2014	\$40,000 a year	Incoming Freshman	Capital Outlay	Purchase, survey, and Observation

**Three Year Goal(s) - Use of Technology to Promote Parental Involvement and Increase Communications with Parents.**

**Goal:** To increase communication with parents/guardians and promote parental involvement.

**Goals need to tie to State Standards. Does your goal tie to State Standards?** YES NO

Objective	Activity	Timeline	Projected Cost	Quantity If Applicable	Category and Source of Funding	Evaluation
All staff will utilize technology to improve communication and promote parental involvement	Maintain a current district web page to inform the community of school business and events	2011-2014	N/A	All Staff	General Fund	Hit counter on web page In-house default homepage Yearly surveys
	Utilize Global Connect telephone system improve Parent communication	2011-2014	\$1600	All Households	General Fund/E-Rate	Date received Global Connect and Community feedback
	K-12 e-mail system	2011-2014	N/A	All staff and students have access Grade 7-12	N/A	Feedback from students, staff, and community
	Infinite Campus and Parent Portal	2011-2014	N/A	All Households	N/A	Feedback from students, staff, and community
	Maintain classroom web pages	2011-2014	N/A	All Staff	N/A	Reviewed by School District
District will improve on community communication	Channel 101	2011-2014	\$1800	All Staff	Private donations/ State grants	Community feedback
	Blackberry services for Administration	2011-2014	\$2100 data services	7 Admin	General Fund/E-rate	Evaluation by Administration and school board
	School Listserv	2011-2014	N/A	School District wide	N/A	Feedback from community members

**Three Year Goal(s) - Distance Learning and DDN use.** Telecommunication technologies (via a networking system called DDN) are provided through state funds to local districts partially obtained through a statewide application for E-rate funding. In this section the district should list any goals, objectives and activities for educational usage of distance technologies (video-conferencing, virtual high school, and internet-based).

**Goal: The district will continue to provide a robust curriculum that will include distant learning opportunities that will provide students with the skills necessary in the 21<sup>st</sup> Century.**

Objective	Activity	Timeline	Projected Cost	Quantity If Applicable	Category and Source of Funding	Evaluation
Increase students access to courses that will allow them to meet 21st Century Skills	Purchase and keep students informed of courses available	2011-2014	\$1500	Students that meet requirements	General Fund	Grades posted on Transcript

### Projected DDN Usage

Activity	Timeline	Quantity If Applicable	Projected Costs	Source Of Funding
Admin Meetings	2011-2014	25\Yearly	0	NA
Teacher Meetings	2011-2014	15 Yearly	0	NA
Classroom	2011-2014	1-2 Classes/Year	0	NA
Community informational services	2011-2014	15\yearly	0	NA

**Three Year Goal(s) – Telecommunications Services and Equipment.** Explain the district’s plans for the future procurement and expansion of telecommunication services and equipment (data, voice, and video). Include all equipment and ongoing services that you intend to procure to achieve the goals and objectives set forth in this technology plan. Any equipment and/or new or ongoing services for which you intend to apply for E-rate should be included in this section. Provide funding source.

**Goal: To continue to upgrade and improve the telecommunications service and equipment within our school district.**

<b>Goal/Objective</b>	<b>Services</b>	<b>Timeline</b>	<b>Quantity</b>	<b>Projected Costs</b>	<b>Source Of Funding</b>
<b>Increase access to Colony Schools</b>	<b>Internet/ Phone Services</b>	<b>2011-2014</b>	<b>2 Schools</b>	<b>\$2500 a year</b>	<b>E-rate and local funding</b>
<b>Increase access to information</b>	<b>Cell Phone service/ data</b>	<b>2011-2014</b>	<b>7 Admin</b>	<b>\$2100 data plan for email services</b>	<b>E-rate and local funding</b>
<b>Upgrade phone system</b>	<b>Phone. Voice messaging/ paging</b>	<b>2011-2012</b>	<b>All classrooms</b>	<b>\$40,000</b>	<b>E-rate and local funding</b>

South Dakota Department of Education  
Office of Curriculum, Technology, and Assessment  
Technology Plan Submission

**Parkston School District 33-3  
102 C South Chapman Drive  
Parkston, SD 57366**

Submission Date to SDDOE  
**January 31, 2011**

Approved Plan will be effective from  
**July 1, 2011 – July 1, 2014**

Technology Plan Submitted by:

**Tony Kinneberg  
Parkston Technology Coordinator**

[Tony.Kinneberg@k12.sd.us](mailto:Tony.Kinneberg@k12.sd.us)  
Phone Number: 605-928-3368  
Fax Number: 605-928-4032



# District Three Year Goals

The Goals of the Parkston School District must address the needs of the four major areas within our district. These four major areas encompass Professional Development, student's access to technology and academic achievement, infrastructure of the school's technology, and supporting the community in uses of technology.

## 1. Goal 1: Professional Development

As one of the founding members of DIAL (Dakota Interactive Academic Link) the Parkston School District has continued a long-term commitment to technology and professional development. Through the use of teacher surveys, the Parkston School District compiles data to find areas that the district can best use its professional development. The district then will form a plan that best addresses the needs of the staff. These needs can be technology uses in the curriculum or learning new technology skills that can be utilized within the classroom. This commitment is outlined in the following manner.

- A. **Mentoring Programs:** Finding ways to help staff through various mentoring opportunities that can be from within the district, consortiums like the ESA, DIAL, or state programs. Using various technology based lesson plans that other teachers have tried and have posted to the state curriculum web page. This process is ongoing and the cost is budgeted through the district that mainly covers travel, and paying for teacher substitutes that cover their classes. The main evaluation is having teachers returning to the district and become the trainers. The staff will then evaluate the success of the program and determine the effectiveness of using it in the classroom.
- B. **Distant Learning Opportunities:** Offering ways that staff can take college courses for credit for teacher re-certification. Offering DDN sessions with other teachers to exchange instructional strategies. Offer courses that address specific contents instructional practices. Evaluation determined by the effectiveness of the training and having staff become mentors for other staff or districts.
- C. **In-Services:** Allow teachers time to attend professional conferences that can assist with new instructional strategies. Allow teachers to attend TIE Conference to learn about new technology curriculum integration. Provide for technology based in-services that use database driven analyze to improve student academic achievement with specific content areas. Funded by district through state grants and funds made available for professional development. Evaluated by surveys, classroom effectiveness in using the technological tools as observed by administration evaluations.
- D. **One-on-one Assistance:** Provide one-on-one assistance for all staff that want or need assistance incorporating technology into the curriculum. Provide training by Technology Coordinator and Curriculum Coordinator

to use technology in the classroom and assist with setting up equipment and learning how to incorporate streaming video into their curriculum through on-line support. Teachers working together on a technology integrated project. Provide teachers training in using smart board technology and utilize various software applications that have been purchased by the district to improve both writing, math and science skills.

2. **Goal 2: Student access to technology and academic achievement.** The Parkston School District, through the use of student surveys, will monitor and adjust technology curriculum needs. These needs will reflect the technology competencies set by the district to ensure that the curriculum is meeting the needs of our graduating classes; and that the student has the necessary tools to compete in a global economy. 21<sup>st</sup> Century skills will be vital for the success of our students to be able to compete in the global market place.
  - A. **Distant Learning:** Allow students to take distance-learning classes that are not taught within the school's curriculum. These classes can be taught on-line through a web-based course or through video conferencing using the Dakota Digital Network.
  - B. **Digital Portfolio:**( Students determine the reliability and relevancy of Information.) Students create a digital portfolio that can be used to access information from when they graduate. The portfolio is useful for keeping data like resumes, transcripts, writing samples and references. Students learn how to create portfolios by using web design software. This digital portfolio will be uploaded and tracked by the student /parent using the SDMyLife web based interface that is offered through the state of South Dakota.
  - C. **Technology Educational Courses:**( Students analyze the parts of a technological system in terms of input, process, output, and feedback. Students analyze the relationships and the connections between technologies in different fields of study and how they apply to communities.) Students are offered classes that incorporate technology into daily applications. These classes include: Independent Living, Parenting, Industrial Technology and Business. Media Production has been added to ensure students have an avenue to which they can explore communication careers as well as learning various skills related to the 21<sup>st</sup> century.
  - D. **Student Grading Portal:** (Students use technology to locate and acquire information) Allowing students to view their grades through a web-based student data system. This will allow students to track own coursework to view what courses they have taken and what courses they need to take to meet district graduation requirements.
  - E. **Senior Project:** (Students use technology to enhance learning, extend capability, and promote creativity) Senior class will be required to complete a technology based project. This project will incorporate data collection skills, synthesizing data skills, and presentation skills. The student will present their project to a panel of community leaders. The project will be graded and credit will be applied towards graduation.

- F. **Media Production:**( Students analyze the relationships and the connections between technologies in different fields of study and how they apply to communities. Students recognize and demonstrate skills in operating technological Systems. Students understand the purpose of information technologies to communicate with a variety of collaborators) Allowing students to create, produce, edit, script and upload media content for the Parkston Trojan TV channel hosted on local cable channel. Allows students first hands experience in the multimedia field. The course is an outcome project based course that allows students to use the skills necessary for a 21<sup>st</sup> Century world.
- G. **Student email:**( Students exchange information and ideas for an identified purpose through Information Technologies. Students understand the safe, ethical, legal, and societal issues related to technology) Students are required to have an email account for communication with teachers and parents. With email accounts, students also have access to WebCT which is a classroom management site for teachers to use that is provided for by the state.

3. **Goal 3: Improvement of Infrastructure and Technology:** The Parkston School District will yearly upgrade its inventories to show current information about hardware and software within the school district. These inventories are housed both at the school and online at the K-12 Data Center. The projects are evaluated based on need, usage in the classroom, evaluations made by administration, student input as well as community.

- A. **Purchases:** The school district will look at its technology needs on a yearly basis and through use of school wide surveys; the technology committee will make recommendations on the needs of the school district. The evaluation method for these projects will be first, the purchase of these items if they are improvements to the school infrastructure. Second, through observation and survey of these projects by staff, students, and in some cases community members. Laptops for one-to-one are purchased annually. Budget from capital outlay estimated at \$40,000.00. The school provides internet connectivity for colony schools. Estimate cost is \$250.00 per month paid by e-rate and general funds
- B. **Smart Boards and LCD Projectors:** The school will continue to purchase additional LCD projectors to replace the older projectors and will continue to use the Smart boards and Mimio boards in the classrooms. Estimated cost will be \$5000.00 annually to replace or repair. Capital Outlay funds will be used.
- C. **Classroom Sound Systems:** The district will continue to purchase sound system equipment to be placed in the classrooms. The systems are installed to ensure that all students in the classroom are able to hear the teacher and other students wherever they are sitting. The sound system has been utilized in many classrooms and the students have commented on the ability to hear better in the classroom. The comments from the students, and parents that have visited the classrooms, has been very

positive. The district has determined through survey students that the sound system has been very positive and will continue to purchase additional sound systems until all classroom have been completed. The district will purchase these systems out of capitol outlay and over the next three years will have completed the project of installing the systems in all classrooms. The estimated cost will be \$10,000.00 for the project. Project is covered by Capital Outlay funds.

- D. **Security units:** The district will continue to upgrade its video surveillance system. The one objective for the district is to ensure the safety and well-being of all students. The district will use funds from a Capital outlay. Estimated costs are about \$15,000.00 for the project.
- E. **Blackberry and services:** The district will provide blackberries for its administrators so they can communicate through use of email and messaging services. The blackberry will also aid in keeping a list of contacts and schedules that can be used in times of emergency or in everyday scheduling of school related activities. The blackberries will also help with communication when administrators are away from their desks or out of the school district. The cost of the blackberries and service provider will be covered by e-rate for the services and capital outlay for the devices. Estimated cost monthly services \$300.00.
- F. **Security Locks:** The school district will provide additional security features with a keyless entry lock system. This security system will allow the district to control the traffic in and out of the school building. The district believes that the safety of our students is of vital importance and this will help in controlling visitors that are entering our buildings. The system will help with lock down situations that give collect information about who is entering the building and what time of day they are entering.
- G. **Telephone and Bell System upgrade.** The school district will over the next three years update its telephone infrastructure and bell system. The district is looking at options to fully upgrade our whole telephone system that will help with communication within our school. The cost of this project is still in the infancy stage and will be paid for by capital outlay dollars and e-rate funding if available.
- H. **Network infrastructure:** The district monitors annually it needs in servers, switches, access points, software upgrades. The cost for such upgrades comes through capital outlay funds that the district budgets every year.

- 4. **Goal 4: Parental Involvement and Increase Communications with Parents:** The Parkston School District will continue to support parental involvement by using whatever means available, including technology, to ensure that they are informed about their child's educational needs and opportunities. The Parkston School District will continue to support the Parkston community by through training opportunities or using the school facility or equipment when necessary. Goals do tie into State Standards.

- A. **Grade book Parent Portal:** Each parent receives an account that allows them to monitor their child's progress. These accounts help monitor student's grades, attendance while mapping out student's courses so they know which classes they need to take to meet all state requirements for graduation. This is on going and the cost is provided by the state. The evaluation is the feedback we received from the parents on the success they have monitoring their student's progress.
- B. **Website:** The school maintains a website that includes vital information about school events, scholarship opportunities, school newsletters, board minutes, faculty listings, and contact information for the school. Staff will maintain their own websites that parents and students can access. The website will host syllabus for class, lesson plans and contact information. Funded through the state. Evaluation is through feedback from parents, students and community
- C. **Quarterly Newsletters:** Newsletters that are created using publishing software tools in the school. This newsletter highlights student activities as well as information that every citizen living within our community has access to reading. These newsletters help inform the public on the educational goals setup by the district and highlight the progress being made through out the school year. Cost is paid for by the district that includes mailing, printing and publishing the newsletter. Estimated projected cost \$1500.00. The cost comes out of the general fund. Evaluation is determined by feedback given by community members.
- D. **Use of Email:** Staff, student, and parent have access through email accounts. Students in grades 7-12 all have access to email and the parents are encouraged to email their child whenever necessary. The daily data is sent to staff, students, and parents. The daily data keeps the line of communication open so parents are aware of activities that are going on that particular day. Parents can email staff when questions arise and assignments are emailed to students when they are absent from school. Cost is funded by the state
- E. **Global Connections:** This is an automated phone system that can call everyone in our school district either through a LAN line or cell phone and leave messages that are school related. These messages can be school closings, school activities, questionnaires, or in case of emergency. This automated system will cost the district on a \$2 per/student basis.
- F. **District wide Calendar:** The school will continue to use the School In-Fusion online calendar that allows parents and student access to a daily, monthly list of activities as well as lunch menu. Parents are given the option to sign up for email notification so everyday they can receive an email about daily activities. This will help keep parents, students and community members informed of school related items.
- G. **Parkston Trojan Television:** Parents are kept inform through use of local cable channel that is dedicated to the school and community. Santel Communications has partnered up with the school to offer a media outlet to keep our parents and community informed. The channel offers various

types of content that is both entertainment and informational for our whole community. (An example would be the Superintendent addressing the community about the school in his annual state of the district address.) Funding comes from local business support, local grants, capital outlay.

**Goal 5: Community Involvement and Community Support:** The Parkston School District will continue to support the Parkston community through training opportunities or using the school facility or equipment when necessary.

- A. **Community Classes:** The Parkston School District will continue to host community computer classes that include Internet uses, emailing, word processing and other various software. Funded by district
- B. **Distant Learning:** Provide use of DDN Room and training on using the equipment. Find opportunities to use DDN for community members like first aid training for EMTs; courses for child care providers and ag-related topics. Funded by district
- C. **Facility and Equipment:** Provide community access to technology equipment like LCD projector, digital cameras and computers. Allow access to computers for community members to use for internet or e-mailing. Funded by district
- D. **Parkston Trojan Television:** Provides the community with a rich source of information from the school district. The school will use the cable channel to keep parents/community informed about school related events as well as necessary information such as issues/topics such as bullying, sexting, scams, computer issues.

**Goal 6. Integration of Technology with Curricula and Instruction.**  
The staff will incorporate technology using software-based applications to be used in their curriculum.

- 1. **WebCT:** Staff will be trained in utilizing web-based software to use as a tool to help organize and present curriculum to their classroom. Each staff will be expected to use WebCT in one course and be able to use the content tools to incorporate technology. Staff will use the WebCT course to create the possibility of having the course made available to students on-line. Training will be supported from within the district and through teaching the trainer model. No Cost to school
- 2. **Criterion:** Web based application that will allow students to upload their research papers for instant feedback on grammar errors. This software will allow students to correct grammar errors which will allow the student to focus more on content. This software will help students with writing skills across all curriculums and will be available

to students in grades 10-12 with the goal to be made available to all grades K-12 in the next three years. The cost for the district is \$1000.00 annually paid by general funds.

3. **Textbooks on-line:** The district's goal is to look at the possibility of purchasing on-line textbooks. The district will compare data from schools that have purchased on-line textbooks compared to ordering textbooks. This is ongoing; staff has used online textbooks when upgrading their new textbooks in each of the subject areas.
4. **Tablets/Laptops:** The district has purchased tablets/laptops for all grades 9-12. The tablets/laptops are used to incorporate technology into the classroom. Students have access to Internet, email, software applications and web based applications that help incorporate technology into the curriculum. It will be the goal of the district to make tablets/laptops available to elementary and junior high students as well. Tablets/Laptops are purchased out of Capital outlay. Annual cost for incoming Freshman \$45,000.00
5. **Renaissance Learning:** The district has purchased services from Renaissance Learning to help with Title Students in reading and math. This program also is used by other students for testing purposes to ensure that our students are meeting the No Child Left Behind. This is purchased through Title money and general funds by the school district. Annual cost \$1000.00
6. **Quia:** The school district has purchased licenses for teachers to use the classroom management tool in their classroom. Quia allows for multiple uses from grading, testing, surveying, posting and evaluating students in their classroom. Cost per teacher is annual fee of \$45 that is covered by general funds.
7. **Edperformance:** The state has provided us with web based technology that allows us to track student's progress in the area of reading and math skills. The students are tested to see where they are proficient in these skills and what areas are needed for improvement. Cost is through the state.

**Goal 7. Expanding Distance Learning:** The district will continue to invest in ways to use distance learning as an opportunity to expand their educational opportunities. Some areas are offering dual credits from colleges for students, as well as AP courses offered through APEX. We offer a variety of courses through DIAL and the Virtual school of South Dakota. Students are given a variety of distance learning courses when they register for their courses. The courses are funded by the district and in some cases the student/family are required to pay some costs.

**Goal 8. DDN Usage:** The district will continue to use the DDN system that is offered by the state. We use the system various ways from onetime events for elementary, to courses that are offered through the DDN. The district uses the DDN in administrative meetings, athletic conference meetings, community for educational training opportunities and staff for

in-service opportunities.( Projected Administrative meeting 15/annually,  
Elementary 15/annually, community 15/annually, meetings 25/annually)



## Curriculum Integration

The Technology Plan addresses the needs of our district in regards to technical support, professional development and equipment needs. Our Consolidated Applications does provide funds in each of these areas in the technology plan. The funds help support part of the salary for a technology coordinator, in-services that incorporate technology as part of its training and some hardware/software that maybe needed to support the professional development for our staff. Curriculum mapping will be the concentration in our School Performance Plan.

The technology used to support our curriculum must also meet the needs of our School Performance Plan. Our School Performance Plan is an action plan; that with the help of our ESA, is developing ways to improve our curriculum through collecting data from the STEP testing and mapping out effective ways to improve instructional strategies with in the classroom. One component of this plan is, technology integration, to improve student performance in specific content areas. Several areas are being addressed now through the reading content area. The staff trained to use DIBELS by using Palms and reading software to map out student reading skills and monitor areas of strengths and weaknesses in each student's reading abilities. Training is done over the DDN on using the Palm software and certified instructors are coming to each classroom and monitoring the actual testing done by the staff. The ESA plays a vital role in training and the follow up done in each of the professional development opportunities.

The district is currently learning how to incorporate various types of technology that include GPS, Palm, video streaming, WebCT, wireless technology, and multimedia presentations. The high school is using WebCT as a component in classes like Novels, science and history. Students are learning practical experiences with collecting data for their digital portfolios that include resumes, references, bios, and letters of recommendations. Staff is using video streaming to give visual sense to a particular content standard that was not available in the past. The district understands the importance of having a technology coordinator on staff to help with the needs of technology integration and supporting staff with a working knowledge of the equipment. The district provides time for staff development in specific content standard areas that allow for hands on opportunities to incorporate technology. One of the best practices used by the district is train the trainer model where staff is trained in a specific area of technology and they in return train other staff members within the district or consortium.

The district supports distance learning and will continue to address the needs of upgrading equipment and allocating funds for distance learning expenditures. The district provides distance learning for students, staff and community. The district has a long working arrangement with the National Guard to use the facility, which allows them access for meetings and trainings. The DDN is utilized to offer advanced coursed that are not taught in Parkston like French II or Spanish III. On-line courses are offered for advanced web design, agricultural science, and parenting courses. The elementary uses one-time programming as a component to teach a specific content standard. These one-time programs can help take a place of a science lab or other equipment that the school

does not have access to. The district has an invested interest in distance learning and will continue to find ways to utilize it. The district will continue to survey students, parents, and community to find more ways to use the DDN as a learning tool.

The district goal is to prepare our students with 21<sup>st</sup> Century Skills. The district is part of the One-One Classroom Connections Program that puts a tablet in every student in grades 9-12. The Jr/Sr High staff is utilizing software that includes Quia that allows teacher to create sample tests, and Ed Performance for on-line testing to monitor the effectiveness of writing, math and science skills. With No Child Left Behind, the district has to continually evaluate and re-evaluate the success of our technology integration and ensure that the needs of our students are met. Our students need to be ready to enter the 21<sup>st</sup> Century fully equipped with the competitive technological knowledge for the global economy of the future.

## **Inventories**

Inventories are kept online at the state as well as on file in the district. We are in the process of creating a helpdesk using share point on which the inventory is being updated over the next year. The inventories include basic information about the equipment including serial numbers, place of equipment and when it was purchased and if it was replaced, repaired, or damaged. The inventory system will monitor in case of the one-to-one laptop which student has that particular laptop as well as any maintenance done or if the computer has been declared surplus. The help desk will update all software records and will house all the data for all the licenses of software for the district. The district evaluates the software annually and keeps track of any subscriptions that need to be purchased.

<b>Parkston School District Software</b>	<b>License</b>	<b>Quantity</b>
Quia Web License	Individual	10
Altiris Licenses	Individual	596
Windows Operating Licenses (XP) (Windows 7)	Volume License	450
Microsoft Office Suite 2007	Volume License	450
Sun Office	Site License	500
Renaissance Learning Web License	Site License	150
Adobe Academic Software	Individual	50
Adobe Premiere	Individual	3
Adobe Acrobat Pro 9	Individual	10
SmartBoard Notebook	Volume License	100
Mimio Board Software	Individual	25
Synchronize Software	Site License	250
Windows 2008 R2 Server Enterprise	Individual	3
Windows Server Virtual Licenses	Individual	15
FortiClient	Individual	250
I movie	Individual	3
Mac Operating Software version 10	Individual	3
OnGuard 2008	Individual	5
Exacqvision	Individual	5
Logger Pro3	Site License	150
Gamco (Time, Money, Math)	Site License	100
SUI Business Software	individual	5
Wordware	individual	5
Criterion	individual	80
Final Cut Express 4	individual	3
Sunburst Lab software	individual	15
Scanteck Lab Software	individual	15
Frontpage 2000	individual	150
Kidpix	Site License	
Dreamweaver 5	Individual	25
Flash	Individual	25
Adobe Photoshop 7	Individual	25
Adobe Paint	Individual	25
Cornerstone	Site License	
PAWS	Site License	
Print Artist	Individual	5
Sketch pad	Network License	
Hotdog stand	Individual	1
Number sense	Individual	1
Fraction Attraction	Individual	1
Clifford Reading	Individual	1
Dr Seuss	Individual	1
Reader Rabbit	Individual	10
Curious George	Site License	1
Green Eggs and Ham	Individual	1

Cat in the Hat	Individual	1
Get in a Fight	Individual	1
Writng Machine	Individual	1
New Kid on the Block	Individual	1
Picutre Phonics	Site License	1
Math Blaster	Individual	10
Humam Biology	Individual	1
Solar System	Individual	1
Word Munchers	Site License	
Just Grandma and Me	Site License	
Dinosoft	Site License	
Cornerstone Math	Site License	
Oregon Trail	Site License	
Where is Carmen	Site License	
Coin3	Network License	

## Children's Internet Protection Act

The Parkston School Board addresses the Children's Internet Protection Act when it reviews and if necessary amends our technology plan. The Children's Internet Protection Act was last reviewed by the school board when the board reviewed and revised the Acceptable Use policy in the fall of 2010. The district provides information to parents during parent/teacher conferences and answers any questions about internet safety and will hand out reading material on topics that relate to internet safety.

### General Guidelines:

The Internet is an electronic highway connecting thousands of computers all over the world and millions of individual subscribers. These guidelines are provided so that you are aware of the responsibilities you are about to acquire. In general, this requires efficient, ethical and legal utilizations of the network resources. If a Parkston Public School user violates any of these provisions, his or her current access will be terminated in the future and indicate the party (parties) who signed has (have) read the terms and conditions carefully and understand(s) their significance.

### 7.1 General Guidelines

- (1) Students will have access to all available forms of electronic media and communication approved by administration, which is in support of education and research and in support of the educational goals and objectives of the Parkston School District.
- (2) Students are responsible for ethical use of the technology resources of the Parkston School district.
- (3) Access to the Parkston School District technology resources is a privilege and not a right. Each employee, student and/or parent will be required to follow the Acceptable Use Policy.
- (4) Transmission of any material that is in violation of any federal or state law is prohibited. This includes, but is not limited to the following: confidential information, copyrighted material, music downloads, threatening or obscene material, and computer viruses.
- (5) Any attempt to alter data, the configuration of a computer, or the files of another user, without the consent of the individual, school

administrator, or technology administrator, will be considered an act of vandalism and subject to disciplinary action.

## 7.2 Privacy and Safety

Do not go into chat rooms or send chain letters without permission.  
Do not open, use, or change computer files that do not belong to you.  
Do not reveal your full name, phone number, home address, social security number, credit card numbers, password or passwords of other people.  
Remember that storage is not guaranteed to be private or confidential.  
If you inadvertently access a web site that contains obscene, pornographic or otherwise offensive material, notify a teacher immediately so that such sites can be blocked from further access. This is not merely a request; it is a responsibility.

## 7.3 Legal Propriety

Students must comply with trademark and copyright laws and all license agreements. Ignorance of the law is not immunity. If you are unsure, ask a teacher or parent.  
Plagiarism is a violation. Give credit to all sources used, whether quoted or summarized. This includes all forms of media on the Internet, such as graphics, movies, music, and text.  
Use or possession of hacking software is strictly prohibited and violators will be subject to disciplinary action.  
Violation of applicable state or federal law, including the South Dakota Penal Code, Computer Crimes, will result in criminal prosecution or disciplinary action by the District.

## 7.4 E-mail

Always use appropriate language.  
Do not transmit language/material that is profane, obscene, abusive, or offensive to others.  
Do not send mass e-mails, chain letters or spam.  
Students should maintain high integrity with regard to email content.  
No private chatting during class without permission.  
E-mail is subject to inspection by the school.

## 7.5 Consequences

The student in whose name a system account and/or computer hardware is issued will be responsible at all times for its appropriate use. Non-compliance

with the policies of the Tablet/Laptop Handbook or Acceptable Use Policy will result in disciplinary action.

Electronic mail, network usage, and all stored files ***shall not be considered confidential and may be monitored at any time by designated District staff to ensure appropriate use.*** The District cooperates fully with local, state or federal officials in any investigation concerning or relating to violations of computer crime laws. The South Dakota Open Records Act governs contents of e-mail and network communications; proper authorities will be given access to their content.

The school district has used programs as well to address internet safety in the elementary grades that include I-Safe to ensure that the students are aware of internet, email and chat room safety. The district uses Fortinet and Fortigate as its firewall and content filtering that is provided by the state. We use monitoring software to view websites that students are viewing and the district has purchases offsite content filtering for the students that have tablets/laptops to use at home and school. The school provides sessions on sexting and bullying using the internet and social networks to both our students and parents.

The district along with local police have formed a working partnership to help deal with computer related crimes or activities. The district will continue to educate its staff, students, and community to ensure our students are safe from computer related crimes and how important it is to protect one's identity.



## 6. SOFTWARE ON TABLET/LAPTOPS /Desktops

### 6.1 Originally Installed Software

The software originally installed by the Parkston School District must remain on the Tablet/Laptop in usable condition and be easily accessible at all times.

The Tablet/Laptop is supplied with Microsoft® Windows® XP Tablet/Laptop PC Edition operating system and with additional software. Licensed software provided with all new Tablet/Laptops includes but is not limited to:

- Microsoft Office Professional Edition including Word, Excel, Access, FrontPage, PowerPoint & Publisher
- Symantec Antivirus
- Windows Media Player
- Windows Movie Maker
- Adobe Reader
- Photo story for Windows
- Notebook Software

From time to time the school may add software applications for use in a particular course. The licenses for this software require that the software be deleted from Tablet/Laptops at the completion of the course. Periodic checks of Tablet/Laptops will be made to ensure that students have deleted software that is no longer required in class and that the school has not exceeded its licenses.

### 6.2 Virus Protection

The Tablet/Laptop has anti-virus protection software. This software will scan the hard drive and other drives on boot up for known viruses. The virus software will be upgraded from the network. The school's storage server is also installed with virus protection software and hardware.

### 6.3 Additional Software

It is the responsibility of individual students to be aware of additional software programs and files loaded onto their Tablet/Laptop, which are required for classes and/or school activities.

Any additional software must be appropriate for the school environment.

Each student is responsible for ensuring that only licensed software is loaded onto his or her computers.

Violent games and computer images containing obscene or pornographic material are banned.

### 6.4 Inspection

Students may be selected at random to provide their Tablet/Laptop for inspection.

#### 6.5 Procedure for re-loading software

If technical difficulties occur or illegal software is discovered, all files and the hard drive will be re-formatted. Only authorized software will be installed. The school does not accept responsibility for the loss of any software deleted due to a re-format and re-image.

#### 6.6 Software upgrades

Upgrade versions of licensed software are available from time to time. Students will be instructed to upgrade their software from the school's network periodically.

# STUDENTS: INTERNET AND ELECTRONIC MAIL ACCEPTABLE USE POLICY

## PARKSTON PUBLIC SCHOOL ACCEPTABLE USE POLICY

### INTERNET AND ELECTRONIC MAIL

#### PERMISSION FORM

Please read the following carefully before signing this document. This is a legally binding document.

The Internet is an electronic highway connecting thousands of computers all over the world and millions of individual subscribers. These guidelines are provided so that you are aware of the responsibilities you are about to acquire. In general, this requires efficient, ethical and legal utilizations of the network resources. If a Parkston Public School user violates any of these provisions, his or her current access will be terminated in the future and indicate the party (parties) who signed has (have) read the terms and conditions carefully and understand(s) their significance.

#### INTERNET – TERMS AND CONDITIONS

**1. Acceptable Use** – The purpose of providing Internet and Electronic Mail (E-Mail) through State K-12 E-Mail System is to enable students to explore thousands of libraries, databases and bulletin boards while exchanging messages with Internet users throughout the world.

The use of the Internet and E-Mail must be in support of education and research consistent with the educational objectives of the Parkston School District. Use of other organization's networks or computing resources must comply with the rules appropriate for that network. Transmission of any material in violation of an U.S., or state regulation is prohibited. This includes, but is not limited to: copyrighted material, threatening, obscene or lewd material, or material protected by trade secret. Use for product advertisement, commercial purposes, or political lobbying is also prohibited.

**2. Privileges** – The use of Internet is a privilege, not a right, and inappropriate use will result in cancellation of those privileges. The Parkston Public School administration will deem what is inappropriate use and its decision is final. The administration, faculty, and staff of Parkston Public School may request the system administrator to deny, revoke, or suspend any specific Internet user's privilege

**3. Netiquette** – You are expected to abide by the generally accepted rules of network etiquette. These include (but not limited to) the following:

- a. Be polite. Do not get abusive in your message to others. Do not send or display offensive Messages or pictures.
- b. Use appropriate language. Do not swear, use vulgarities or any other inappropriate language. Do not harass, insult, or attack others. Illegal activities are strictly forbidden.
- c. Do not reveal your personal address or phone numbers of students or colleagues.
- d. Network storage areas will be treated like school lockers. Network and school administrators may review files and communications to maintain system integrity and insure that users are using the system responsibly. Users should not expect that files stored on district servers will be private. Trespassing on another's folders, work, or files is prohibited and will result in loss of privileges. Messages relating to or support of illegal activities will be reported to the authorities.
- e. Do not use the network in such a way that you would disrupt the use of the network by other users (intentionally wasting limited resources).
- f. All communications and information accessible via the network should be assumed to be private property.

**4. No Warranties** – The Parkston Public School District makes no warranties of any kind, whether expressed or implied, for the service it is providing. The Parkston Public School District will not be responsible for any damages you suffer. This includes loss of data resulting from delays, non-deliveries, or service interruptions caused by its own negligence on your errors or omissions. Use of any information obtained via the internet is at your own risk. The Parkston Public School District specifically denies any responsibility for the accuracy or quality of information obtained through its services. The Parkston Public School District cannot be

responsible for inappropriate or offensive material you encounter on the internet. If offensive material would cause you personal embarrassment or other emotional or psychological damage you should not use the system.

**5. Security** – Security on any computer system is a high priority, especially when the system involves many users. If you feel you can identify a security problem on internet, you must notify a system administrator. Do not demonstrate the problem to other users. Do not use another individual's account without written permission from that individual. Attempts to login to internet as a system administrator will result in cancellation of user privileges. Any user identified as a security risk or having a history or problems with other computer systems may be denied access to the internet.

**6. Vandalism** – Vandalism will result in cancellation of privileges. Vandalism is defined as any malicious attempt to harm or destroy data of another user, internet or any of the above listed agencies or other networks that are connected to the state k-12 email system. This includes, but not limited to, the uploading, creation or intentional transition of computer viruses.

**7. Exception of Terms and Conditions** – All terms and conditions as stated in this document are applicable to the Parkston Public School District. These terms and conditions shall be governed and interpreted in accordance with policies of the Parkston Public School Board, the laws of the state of South Dakota and the United States of America.

### **PERMISSION FORM**

I understand and will abide by the above terms and conditions for internet. I further understand that any violation of the regulations above is unethical and may constitute a criminal offense. Should I commit any violation, my access privileges may be revoked, school disciplinary action may be taken and/or appropriate legal action.

**USER'S FULL NAME (PLEASE PRINT)** \_\_\_\_\_

**USER'S SIGNATURE** \_\_\_\_\_

**DATE** \_\_\_\_\_

**HOME ADDRESS** \_\_\_\_\_

**HOME PHONE** \_\_\_\_\_ **GRADE IN SCHOOL** \_\_\_\_\_

**PARENT OR GUARDIAN** (If the student is under the age of 18, a parent or guardian must also read and sign this agreement)

As the parent or guardian of this student, I have read the terms and conditions for internet access. I understand that this is designated for educational purposes and the Parkston Public School District has taken available precautions to eliminate controversial material. However, I also recognize it is impossible for Parkston Public Schools to restrict access to the network. Further, I accept full responsibility for supervision if and when my child's use is not in a school setting. I hereby give permission for my child to access the internet and E-Mail and certify that the information contained on this form is correct.

**PARENT OR GUARDIAN NAME (Please Print)** \_\_\_\_\_

**PARENT OR GUARDIAN SIGNATURE** \_\_\_\_\_

**DATE** \_\_\_\_\_

## **Distance Learning Mission Statement**

The Parkston School District 33-3 believes that Teaching and Learning is an active, engaging process that be supported through the use of distance learning technology. Students can experience an alternative learning environment while taking courses that are challenging; student oriented, technology immersed, and affordable to school districts.

The students learn time management skills, organizational skills and technology skills like how to use course management software like WebCT or Blackboard. Distance Education provides the learner an opportunity to take courses and one-time programming events that many rural schools in South Dakota cannot offer because of facility or lack of staff/funds. The district sees distance education as a necessity to meet curriculum needs that are not offered and will continue to investigate ways to better utilize the advancing technology.

The school district currently follows all the policies that are set up by our consortium for distance learning. These policies deal with issues that are outlined in the technology plan guideline and can be found on the attached DIAL Virtual School Learning Policy document. (See attachment)

# Distance Learning Proposed Policy

## Distance Education

### Virtual/Online Courses

All distance education programs and courses will be consistent with the District instructional goals and aligned with South Dakota's academic standards, curriculum framework and assessment.

Students seeking to take a course through distance education must meet with the guidance counselor and/or principal before registering for a distance learning course. All registrations will be done by the Parkston School District. Courses will be accepted from the Virtual High School of South Dakota, Dual Credit courses from in-state institutions and from out of state institutions on a case by case basis. The courses that will be made available to the students will be the courses that Parkston High School does not offer, or in extreme situations, due to scheduling conflicts, a course that is offered at Parkston High School can be taken from the Virtual High School. If a student has to take course for credit retrieval and the student elects to take the course from the Virtual High School, the student will not be eligible for senior privileges. The courses that are taken for dual credit may not be accepted by all colleges and universities, so it is the responsibility of the student to check to see if the credits are accepted by the college or university they plan on attending.

Courses that will be put on the Parkston High School transcript will be those courses that come from the Virtual High School of South Dakota and any course that is labeled as dual credit from a state institution. Payment for the course and the textbooks, will be paid for by the district as long as the course is put on the high school transcript.

AP courses that are offered through the Virtual High School will be paid for by the school district as long as the student maintains a C average. Once the grade drops below a C average the cost of the course will be the responsibility of the student. It is also the responsibility of the student to pay for the AP exam if the student elects to take the exam.

High School students may earn a maximum of four units of academic credit unless otherwise specified in the student's Individualized Education Plan to be applied toward graduation requirements by completing virtual/online courses accredited by the South Dakota State Board of Education.

All students must meet with the guidance counselor and principal to confirm that the student possesses the maturity level needed to function effectively in an online learning environment.

Students are required to carry 6 courses each semester. Within that 6, classes taken from the Virtual High School and any dual credit course will count. A student taking a course from any other institution will be taken during that students study hall. If a student wants to take two courses from another institution, it will be on a case by case basis.



**DIAL Virtual School**  
 c/o Mid-Central Educational Cooperative  
 PO Box 228  
 Platte SD, 57369  
 (605) 337-2636  
 Fax: (605) 337-2271  
[www.sddial.org/ilc/vschool](http://www.sddial.org/ilc/vschool)



**DIAL Virtual School  
 Distance Learning Policies**

August 5, 2007

1. **Purpose.** The purpose of this booklet is to provide administrative, classroom and student policies governing the DIAL Virtual School classes.
2. **General.** Teachers and administrators of the DIAL Virtual School will review these policies annually. Questions or recommended changes should be submitted to:

John Heemstra  
 Director, DIAL Virtual School  
 821 N. Capital Street  
 Mitchell, SD 57301  
 or email: [john.heemstra@k12.sd.us](mailto:john.heemstra@k12.sd.us)  
 phone: (605) 995-3065

3. **Contents.** The policies in this booklet are organized into the following 3 sections:

Part I - Administrative Policies	page 1
Part II - Classroom/Instructional Policies	page 6
Part III - Student Policies	page 8

**Part I. Administrative Policies**

1. **School Administrator Contact.** Each participating school will designate an administrator as the contact person for student management and communications. This person will:
  - a. Provide the name, address, and phone number to DIAL Virtual School for developing a point of contact listing that will be provided to all schools and distributed to schools. Please notify us if changes are made.
  - b. Receive updates and information regarding future programs. Distribute this information within the school district as needed.

2. **Student Preparedness.** Students enrolled in distance learning classes need the necessary traits required to be successful in distance learning classes.  
A successful distance learning student should:
  - a. Be committed to completing all assignments on time with limited monitoring.
  - b. Be comfortable helping other students.
  - c. Be a self-disciplined, courteous person.
  - d. Be comfortable with technology.
  - e. Be able to work independently to complete tests and quizzes.
  - f. Be able to work in a small group or alone.
  - g. Be willing to actively participate in the distance learning class.
  - h. Be willing to treat the on-site facilitator as an extension of the teacher.
  - i. Be willing to complete the Online WebCT Orientation if taking an online (WebCT class).
  
3. **IEP Information.** It is the district's responsibility to inform DIAL Virtual School teachers of students enrolled in DIAL Virtual School classes who have an IEP. The special education teacher in each school should contact the DIAL Virtual School distance teacher regarding students on an IEP in that school prior to the beginning of the distance class. Distance teachers should be included in team meetings via videoconference when appropriate.
  
4. **School Cancellation.** If the originating school cancels classes, any distance classes from that site will not taught that day. If the originating school is in session, and one of the remote schools cancels classes, then the host teacher will determine what adjustments are necessary. DIAL Virtual School will notify schools via email or phone of class cancellations. The syllabus will provide information for facilitators regarding class activities when remote schools are in session and the originating site is not.
  
5. **Late Starts, Early Release or Special Events.** If a class starts late the teacher or DIAL staff will inform the receiving schools of the adjusted schedule. If there are schedule changes at the receiving school, the facilitator will inform the DIAL teacher as soon as possible.
  
6. **School Calendar.** The starting/ending date for distance learning classes will be based upon common start/end dates for the schools. Other holidays, in-service days or non-class days are based on the DIAL Virtual School Calendar provided to each school and posted at <http://www.sddial.org/ilc/vschool/calendar.htm>. Facilitators will provide a copy of their district calendar to the DIAL teachers.
  
7. **Providing Class Textbooks and Materials.** DIAL Virtual School will provide class textbooks and instructional materials. These materials will be provided prior to the beginning of the class and will be returned to DIAL at the end of the school year unless special arrangements are made to retain materials for the next school year. Schools will be responsible for arrangements to return instructional materials to DIAL and for the cost of any damaged or lost materials.



**8. Class Fees and Drop Date.** In an effort to build a sustainable model for distance learning, DIAL Virtual School charges student fees for classes. These fees will be reviewed each year and may be modified based on actual class costs and any grant funding available. Schools will be invoiced once each semester for their student enrollment that semester. Costs for the 2007-08 school year are shown below:

- 1 - 9 students \$310/student/class/semester
- 10 - 19 students \$300/student/class/semester
- 20 - 29 students \$290/student/class/semester
- 30 + students \$275/student/class/semester

We realize that distance learning may not fit all students' learning style, so we allow a two-week, grace period from the start of the DIAL academic calendar before determining the final enrollment for billing purposes. Billing will be based on the district's student enrollment two weeks after the start of each semester based on the DIAL Virtual School calendar. For the 2007-08 school year this will be September 7, 2007 (for fall semester) and January 17, 2008 (for spring semester).

**9. District Agreement.** Each district will submit an agreement signed by the superintendent/CEO and School Board Chairman. A copy of the agreement is included in this policy.

**10. Class Facilitator.** Participating schools will have a facilitator present for each distance learning class received. This may be an administrator, teacher, para-educator or other staff member. Expectations for class facilitators are specified in a separate handout titled "DIAL Virtual School Facilitator Guidelines".

**11. School Improvement.** DIAL Virtual School teachers should be included in any school improvement processes when possible.

**12. Parent – Teacher Conferences.** DIAL Virtual School teachers will be available for parent-teacher conferences via videoconference. Opportunities to do this during the year are encouraged and desired. Please coordinate this directly with the teacher well in advance of the scheduled date.

**13. WebCT UserIDs.** Students enrolled in online (WebCT) classes will need a WebCT userID/account and those students enrolled in Web Design classes will also need web space. UserIDs will also be needed for facilitators of online classes. The District Technology Coordinator should request userIDs/accounts and web space through the K12 Members site at <https://members.k12.sd.us/>. The district will email the userIDs to DIAL Virtual School (email to John Heemstra [john.heemstra@k12.sd.us](mailto:john.heemstra@k12.sd.us) or Karen Peters [Karen.peters@k12.sd.us](mailto:Karen.peters@k12.sd.us)) before the start of class so students and facilitators may be granted access to the appropriate online/WebCT class.

**14. South Dakota Virtual High School (SDVHS).** The DIAL Virtual School is an approved provider for the SDVHS, [www.sdvhs.k12.sd.us](http://www.sdvhs.k12.sd.us). All SDVHS and DIAL distance courses have been approved by the South Dakota Department of Education to ensure they meet the state's high academic standards. Official registration for DIAL classes must be done through the SDVHS online registration system and students may not begin classes until SDVHS registration is complete. Each school district has a designated individual to complete SDVHS registration and enrollments will be accepted only from school districts and not from individual students or parents. See [www.sdvhs.k12.sd.us](http://www.sdvhs.k12.sd.us) for more information or SDVSH contact.

## **Part II. Classroom/Instructional Policies**

### **1. Class Type and Size .**

a. Interactive Video (ITV) – ITV classes use live, two-way video conferencing over the Digital Dakota Network (DDN) and meet at a scheduled time. Students are able to see and hear the teacher and other students which make this similar to traditional face-to-face classes. These classes will be limited to four remote sites and a total of no more than 25 students.

b. Online (WebCT) – Online classes are done over the internet using the WebCT course management system. Students will receive a WebCT user name and password to access their course assignments and materials. Each student will determine a designated time period during the school day to access work in their class. Students may also access their class anytime and anywhere with an internet connection. Online classes will be limited to a total of 20 students.

c. Blended Classes – These classes use a combination of ITV and WebCT. Students typically have several ITV sessions each week with assignments done over WebCT on other days.

### **2. Discipline**

- a. Students are required to sign and abide by the guidelines of the Distance Learning Student Behavior Policy. A signed copy of the policy will be maintained in each student's record and submitted to class instructors.
- b. Class facilitators monitor, and correct if necessary, student behavior through their physical presence in the classroom.
- c. Teachers are expected to maintain usual classroom order, but shall not be held liable for behavior of students at remote sites.
- d. In the event of behavior problems, the teacher will notify remote site personnel as soon as possible. Remote site personnel should handle behavior problems.
- e. Unresolved or ongoing problems will be handled in accordance with the procedures listed on page 8-9 of this policy.
- f. Distance learning students are required to follow their local school policies.

**3. On-site visits.** Teachers are encouraged to visit and teach from the remote sites once each semester.

**4. Distance Class Evaluation.** Students and facilitators in DIAL Virtual School classes are asked to complete a survey evaluating distance classes each semester.

**5. Video Taping.** The ITV classrooms have the capability of video taping. If a student is absent from the remote site can tape a class that can then be reviewed to make-up the missed class. The teacher may tape the remote sites during class to review presentations or class projects. Videotaping can also be used as a discipline tool.

**6. Attendance.** Attendance in class is critical to student success. Local attendance policies will apply to students taking distance learning classes.

**7. Make-up Work.** Students are expected to make-up assignments prior to class for known absences and after class for unexpected absences. The general guideline for turning in make-up work is to allow one day for each day missed. Special situations will be at the discretion of the teacher.

**8. Grading.** DIAL Virtual School teachers will provide a percentage score for work done in the distance classroom. Grades will be computed in accordance with the local grading policy. DIAL teachers will provide periodic updates to the class facilitator with the student scores. A "grade report" (with student percentages) will be sent to the district administrative contact within two weeks after the end of a quarter. Please contact the DIAL teacher for questions regarding student scores.

<b>Quarter</b>	<b>Start</b>	<b>End</b>
1 <sup>st</sup> Quarter	22-Aug-07	23-Oct-07
2nd Quarter	24-Oct-06	21-Dec-07
3rd Quarter	3-Jan-08	6-Mar-08
4th Quarter	10-Mar-08	16-May-08

**9. Student – Teacher Communications.** Effective and timely communications between students and teachers is essential to the success of a distance learning class. A variety of methods exist for communications including DDN two-way video, email, telephone, fax and face-to-face visits. Teachers will provide an email address and telephone number in their course syllabus to be used for student contact. It is possible to schedule special DDN video connections outside the school day or during the school day if needed and this should be coordinated through the class facilitator and teacher. Instructors will reply to student email or phone calls within 24 hours on school days and on the next class day when received over the weekend.

## **DIAL Virtual School Distance Learning Student Policy**

The DIAL Virtual School is an organization that provides distance learning classes to South Dakota schools. Using distance learning, school districts can receive courses that normally would not be offered because of low enrollment or a lack of qualified teachers. The two-way, interactive, video technology or online WebCT course management system used for these classes allows a teacher to teach from one location with students at one or more different schools. Because of the unique aspects of the distance learning classes, certain standards are expected of the participating students. This policy is intended to make both the students and the parents aware of these standards.

**DIAL Virtual School Student Code of Conduct.** As a student taking a distance learning class I am aware that:

1. High standards are expected of me as a student. My cooperation and appropriate attitude are needed to maintain a positive teaching and learning environment in the online or DDN classroom.
2. Appropriate language is expected and required for all classes, whether face-to-face, DDN two-way video, and for email and WebCT discussions.
3. I am expected to make a commitment to academic integrity. This means:
  - a. Your work on each assignment will be completely your own.
  - b. Your collaboration with another classmate on any assignment will be pre-approved by your instructor.
  - c. You will not practice plagiarism in any form. Plagiarism is defined as copying or using ideas from another person, on online classmate, or an Internet or print source) and presenting them as your own.
  - d. You will not allow others to copy your work.
  - e. You will not misuse content from the Internet.
4. Because of the technology, anything I do in the classroom can be video taped or seen by others and emails or discussion postings are stored electronically.
5. I am expected to comply with my local school district "Acceptable Use Policy" regarding use of computers and the Internet as well as other local district policies.
6. The following classroom procedures must be followed:
  - a. Interactive Video Classes
    - 1) Students will sit within camera view at all times.
    - 2) Students will treat the equipment in the classroom with care.
    - 3) Students will follow all other rules specified by the teacher and classroom facilitator.

b. Online (WebCT Classes)

- 1) Students will complete the DIAL Virtual School Online WebCT Orientation before beginning an online class.
- 2) Students will log into their class each school day or every other day if on a block schedule and complete and submit assignments in accordance with the class due dates.
- 3) Students will follow all other rules specified by the teacher and classroom facilitator.

The procedures for students who cannot follow the above listed rules are listed below:

**First Offense:** The students will be given a verbal warning and told that his/her parents or guardian will be notified by letter of the infraction. The classroom teacher will send the letter to the parents or guardian. A copy of the letter will also be sent to the student's principal.

**Second Offense:** The student will be removed from the class with a failing grade recorded.

**Severe Misconduct:** For the first offense, the student will be removed from the class.

Students are also subject to their local school's behavior and discipline policy for any misconduct during a distance learning class.

### **Additional Student Information**

**Who's watching and listening to you?** You should assume anytime you are in your DDN Video classroom that someone is watching or listening to you. Just because you do not see another site on the TV monitors doesn't mean another site can't see or hear you. If your site is connected in a conference you can be seen or heard or video taped. Additionally online discussion boards and emails should be considered public information since they may be viewed by other participants in the class. Don't embarrass yourself or your school by doing or saying something you wouldn't want anyone else to see or hear.

**Class handouts.** Some handouts and class materials are available on-line. Others will be sent to the class facilitator and distributed by them. If you do not have needed materials, contact your facilitator.

**Submitting material to the teacher.** Your facilitator for two-way video classes will be responsible for mailing, faxing, or delivering materials such as homework, tests, or other papers to the teacher. You are responsible for getting these items to your class facilitator by the required due date. If you are taking online (WebCT) classes you may be required to submit your assignments online. Check the class syllabus for procedures in your classes.

**Contacting the teacher after class.** If you need to contact your teacher outside of normal class times you should make arrangements with your facilitator to either phone the teacher or set up a meeting using the DDN. It is possible to schedule a video connection outside of class time either before or after school. All DIAL teachers have Email and this is the easiest method of contacting your teacher. They will provide an email address in their syllabus. If you have a question or problem, don't wait to contact your teacher. They can't see your puzzled face or read your body language in class so you need to take the initiative to contact them.

**Grading Scale.** Your school will be provided a percentage score for your work in DIAL Virtual School distance classes. Grading will be done in accordance with the local district policy and your school assigns the letter grade and provides course credit.

**Attendance.** Attendance in class is critical to student success. Local attendance policies will also apply to students taking distance learning classes.

**Make-up Work.** Students are expected to make-up assignments prior to class for known absences and after class for unexpected absences. The general guideline for turning in make-up work is to allow one day for each day missed. Special situations will be at the discretion of the teacher.

**DIAL Virtual School Website** - <http://www.sddial.org/ilc/vschool/>

Taking distance learning classes can be fun and challenging. As you take advantage of these new opportunities, be prepared for some new experiences. If you go into the class with learning goals and with a positive attitude, you will be successful.

**This section to be completed and signed by student and parent/guardian**

I have read and understand the DIAL Virtual School student policy and agree to comply with this policy.

\_\_\_\_\_  
Student signature

\_\_\_\_\_  
Date

Parent or Guardian contact information:

Name: \_\_\_\_\_

Mailing Address: \_\_\_\_\_

\_\_\_\_\_

\_\_\_\_\_

Home Phone: \_\_\_\_\_

Work Phone: \_\_\_\_\_

\_\_\_\_\_  
Parent or Guardian signature

\_\_\_\_\_  
Date

\_\_\_\_\_  
School Administrator signature

\_\_\_\_\_  
Date

A copy of this signed agreement will be returned to your distance learning teacher and a copy will be maintained in the student's records at the student's school. This must be completed within two weeks after the start of a class.



## **Collaboration with Adult Literacy**

The district's policy is to encourage adult educational opportunities within our community. We hold computer related classes in the fall and spring for our community members. The courses include internet, email, software applications and digital photography. We have courses in gardening using DDN to connect various sites while the training is occurring. We provide training opportunities for EMTs and fireman to use our facility and the technology that is made available to them. We open our DDN room for community members to take advantage of distance learning and make available the use of our computer labs when requested by the public. The district's policy is to create an environment of learning that is both available to students and community alike.

## Three year Telecommunications Services and Equipment Policy

The district will annually assess its cellular plan to determine if it meets the needs of our district. (input from administrators) Every three years the plan allows for upgrade of cell phones. The school invests in an automated phone messaging service that is paid by general fund dollars. The system is maintained off site and the district pays for its services. The district plans to update its phone system in 2011 which will include a new paging system for each classroom. The district evaluates the need for new equipment on an annual basis and in most cases it is done on a need basis.

**Data:** The district evaluates its network needs annually and updates servers, switches, access points as the need arises. Most of the needs for data lines, domain names are taken care of by the state or local telecommunications companies. The state monitors our routers and does the maintenance of firewall and content services.

**Video:** The district repairs or replaces all types of video devices. We evaluate if there are needs to upgrade and then annually purchase what video equipment is needed. Most cases the video equipment has wore out or become obsolete for what we need in the district.

The district has a policy to ensure all discard equipment is properly disposed of and is careful not to harm the environment. We have contracted with a company that comes and picks up all obsolete technology equipment.

## **E-Rate Document Retention Policy**

**The Parkston School District maintains all documentation for filing e-rate applications on file within our district office. The district maintains all documentation to show the USAC Forms and certifications from previous years. The district compiles all USAC letters for receipt of notification and all other forms that is part of the e-rate application. The district has on hand in the district office the technology plan and the certified technology plan letter from the state of South Dakota. All contracts for bidding and vendor information are kept on file in the district office as well. Parkston School District has undertaken the necessary action for CIPA and ensures child internet safety with appropriate content filtering. At the beginning of the year, parents are informed about the district's technology policies and periodically throughout the year are given opportunities to learn more about the technologies in the district as well as the safety aspect that goes with technology.**

## Evaluation Process

The Evaluation process is the most important process if changes are to be implemented and that your technology goals are either met or need to be evaluated. Our goal is to annually review our plan and find out what area were successful and what areas not. The best evaluation tool is to go back and evaluate the professional development for your staff. We keep a list of flyers that explain what the training was about and then evaluate whether those trainings were successful for our staff or not.

We then evaluate our distance education classes and determine if the classes met the needs of our students and how successful it was for meeting our goals. If the classes are not successful we need to find other means to provide for our students. The process is the same for our community members. We must evaluate the needs of our community on an annual basis and then find learning opportunities that will fulfill their needs.

Finally we evaluate our curriculum to ensure that our students are reaching our technology goals. This process is ongoing and being evaluated by staff and administration. Your evaluation tool and what changes are made on an annual basis determine the success of you technology plan.

# **Appendix**

**Crisis Management Plan**

**Schematics**

**Laptop Policy**

Draft

**PARKSTON SCHOOL  
CRISIS MANAGEMENT TEAM  
and  
Building Chain of Command**

Crisis management team members to be contacted to assist in a crisis.

Shayne McIntosh  
Superintendent

605-928-7129  
Home Phone Number

Joe Kollmann  
High School Principal

605-928-3331  
Home Phone Number

Rob Monson  
Elementary Principal

605-928 3731  
Home Phone Number

Jim Akre  
Team Member

605-928-3956  
Home Phone Number

Delaine Branum  
Team Member

605-933-1214  
Home Phone Number

Lyle Weekly  
Team Member

605-928-7301  
Police Dept. Number

---

Team Member

---

Home Phone Number

Outside Command Post Location - Parkston High School Football Field

Sacred Heart Catholic Church  
(Alternate Site)

Salem UCC Church  
(2<sup>nd</sup> Alternate Site if Necessary)

605-928-3862  
(Alternate site telephone number)

605-928-4038  
(2<sup>nd</sup> Alternate site telephone number)

# Draft

## POWER OUTAGE

The Superintendent should prepare for a potential power outage by making sure the building has alternate light sources in the event of power failure. Flashlights and batteries should be placed in classrooms or stored in easily accessible locations throughout the building to ensure safe passage of students and staff in the event of power failure and no lighting. Batteries should be kept in their original packages so they won't lose their charge prior to the time they are needed. Determine the location of your analog telephone line for use along with your building cell phones when the power is out. Also, make sure you have a hard copy of all student schedules in your school office. Staff members should be alerted that if they are not supervising students at the time of the power outage, they should automatically report to the school office. With those preliminary actions in place, the following steps should be followed.

1. Contact Operational Services to report the power outage and for assistance in determining the potential length of the outage.
2. Notify the Principals of this info.
3. Have the crisis team and other staff not supervising students report to the school office.
4. Establish your crises center of operation. Have a secretary or other designated person stay in the office to monitor calls on the analog telephone.
5. Distribute walkie-talkies and flashlights as needed.
6. Immediately send staff to inform all students and teachers to stay in their present location until further notice. Do not allow movement of students in the halls until definite plans have been made regarding safe procedures for student movement.
7. Determine the cause of the power outage. If there is a downed power line, station a custodian with a walkie-talkie in the vicinity at a safe distance to maintain constant communication about the situation, facilitate communication with repair crews and insure that no one will inadvertently walk into an unsafe area. The custodian should notify you when the power has been turned off in the "hot zone."
8. Station a staff member at the front door to monitor traffic into an out of school. In addition, this person should indicate to the press that the principal would be more than willing to talk to them at the conclusion of the power outage but do not allow them into the building without the approval of the principal.
9. Secure all doors and make sure no one including itinerant staff, students, teachers or parents leave the building except through a door that has been determined to be safe and secure from the potential of walking into a downed power line.

# Draft

23. Debrief with the Crisis Team to make any adjustments necessary to the plan.

## **Notification Procedures for Power, Phone, or Network Outages**

From time to time, schools experience outages in electrical power, phone service, or the computer network. Principals or designees are to use the following procedures in response to the specific type of outage.

### **Electrical Power Outage:**

#### **Building Principal -**

- \* contact Provider to report the power outage and for assistance in determining the potential length of the outage
- \* contact the Superintendent
- \* send e-mail notification of power outage to All Administration, All IPC, All Lead Clerical, All Central Services
- \* send e-mail notification when power is restored

### **Phone Service Outage:**

#### **Building Principal -**

- \* contact Purchasing Department to report the phone outage and for assistance in determining the potential length of the outage
- \* contact the Superintendent

### **Computer Network Service Outage:**

#### **Building Principal -**

- \* contact Mr. Kinneberg to notify network is down

#### **Assessment, Technology, & Information Services -**

- \* send e-mail notification that building is off network to All Administration
- \* send e-mail notification when network service is restored



## Typical Schematic for Parkston School District Classroom

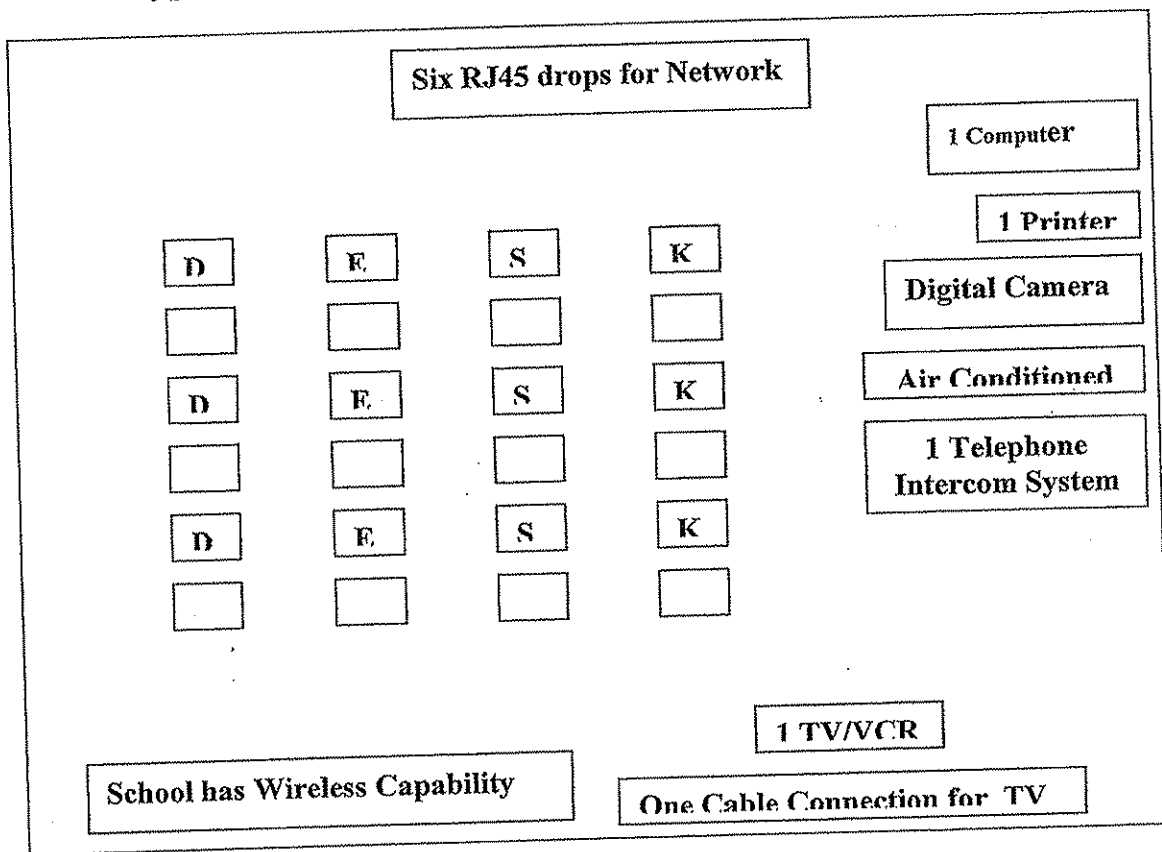

## Typical Schematic for Computer Lab

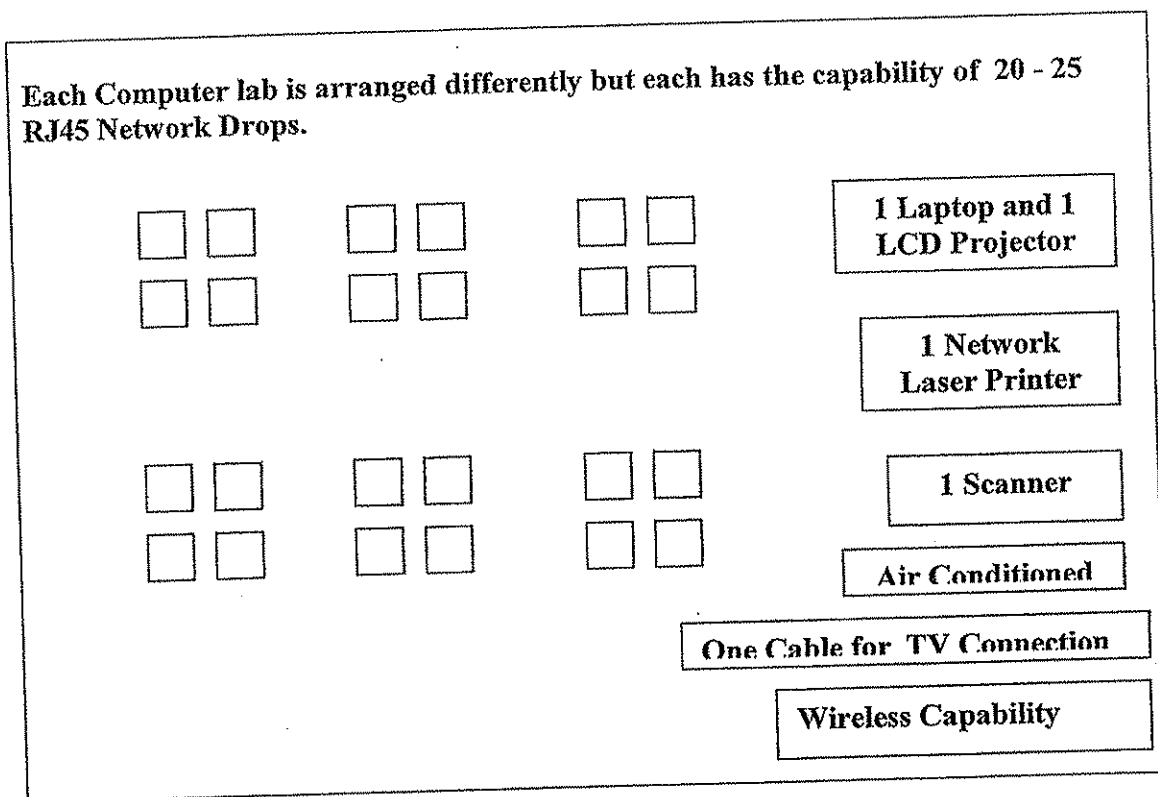

## Schematics for Distant Learning Room

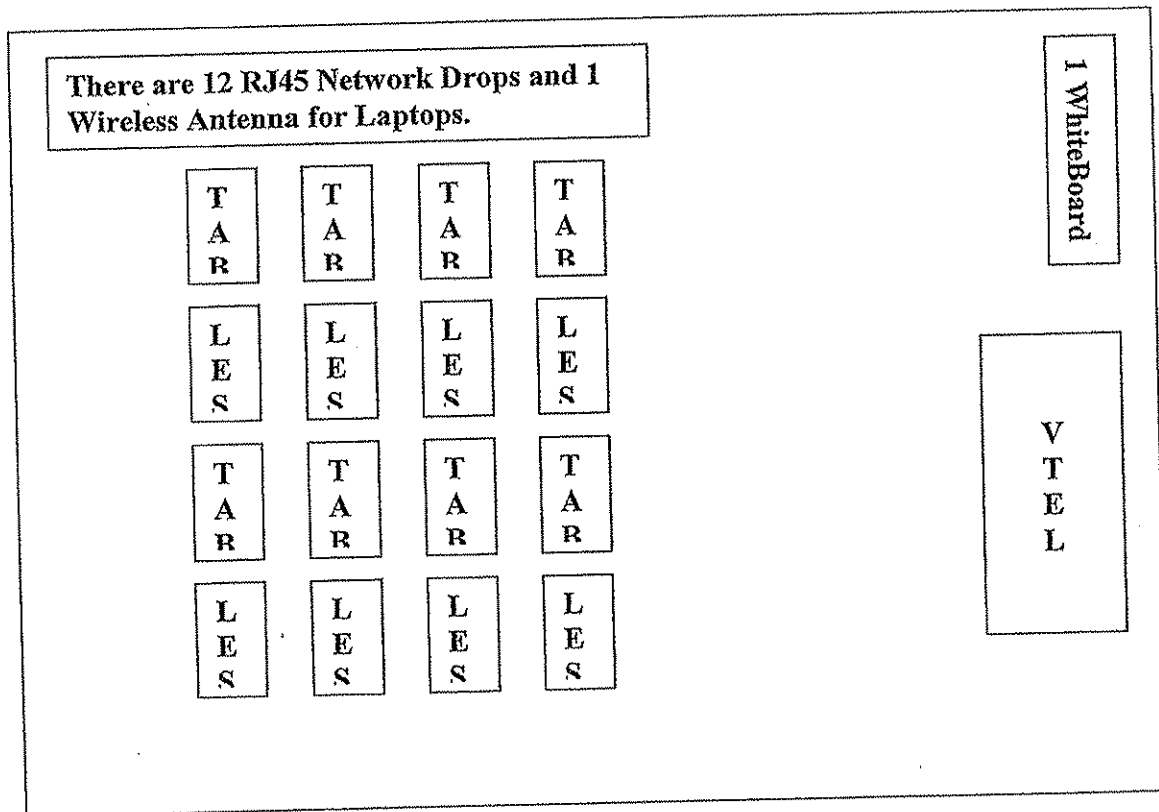

## Typical Old Elm Colony Class Room

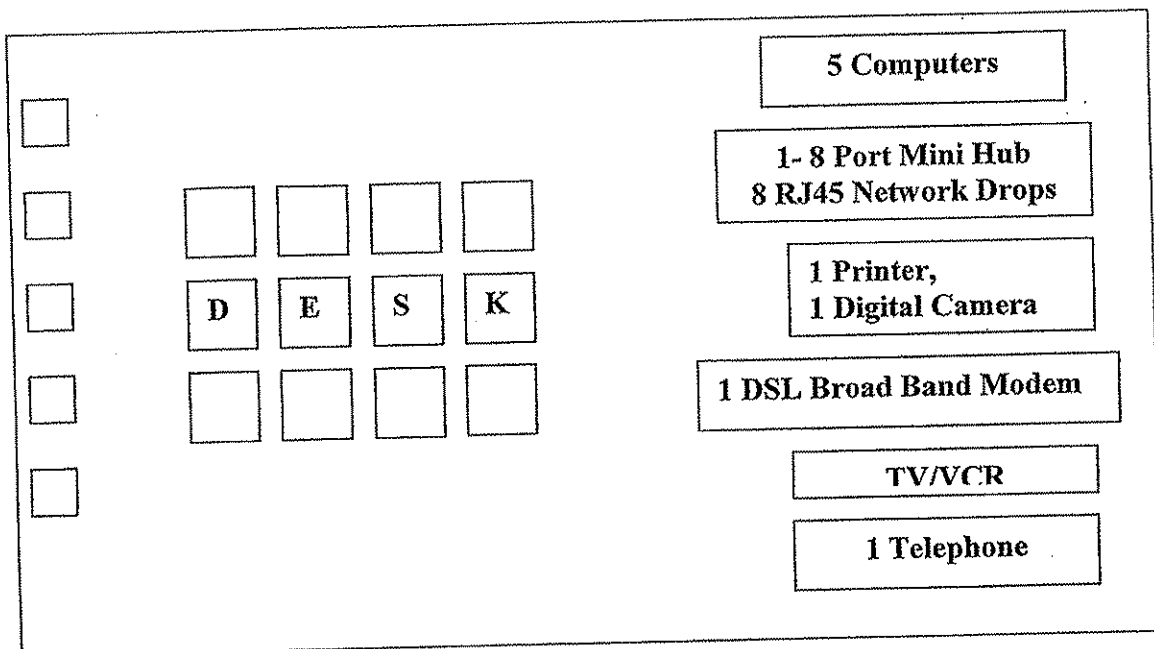

## Typical New Elm Colony Class Room

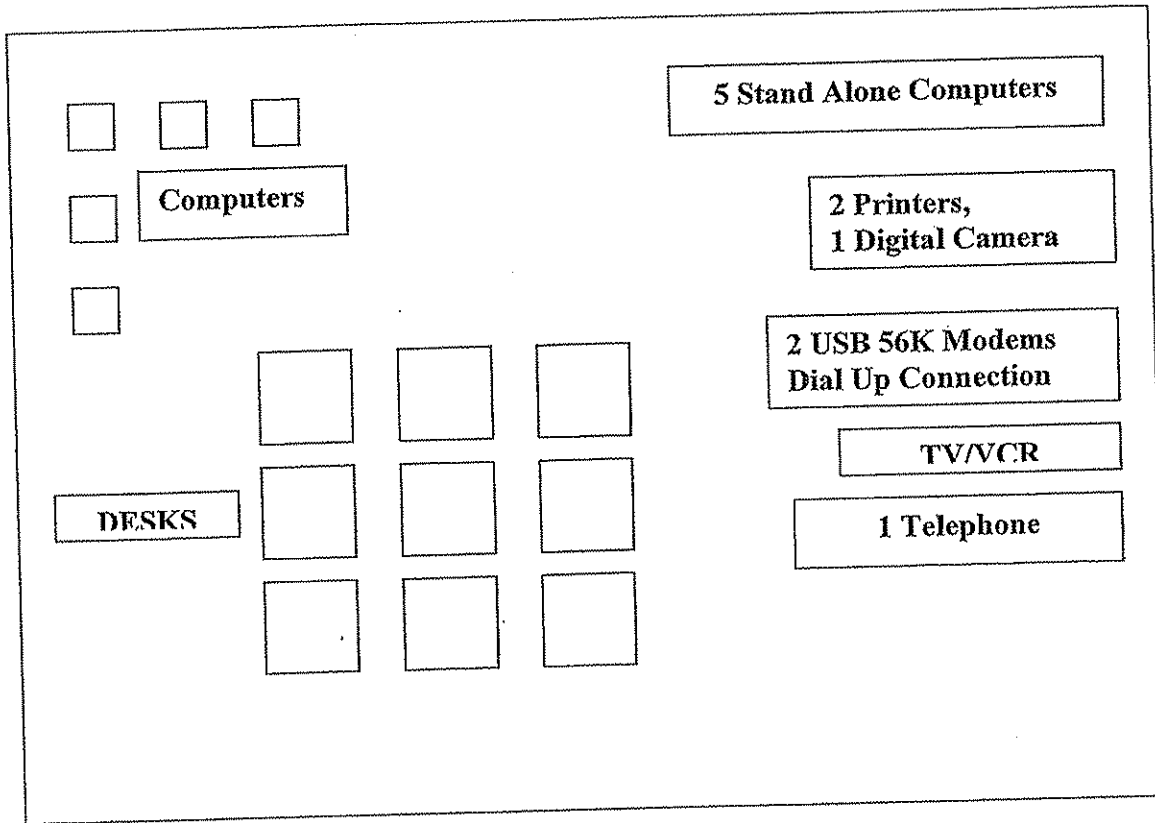

## Typical Interim School Class Room

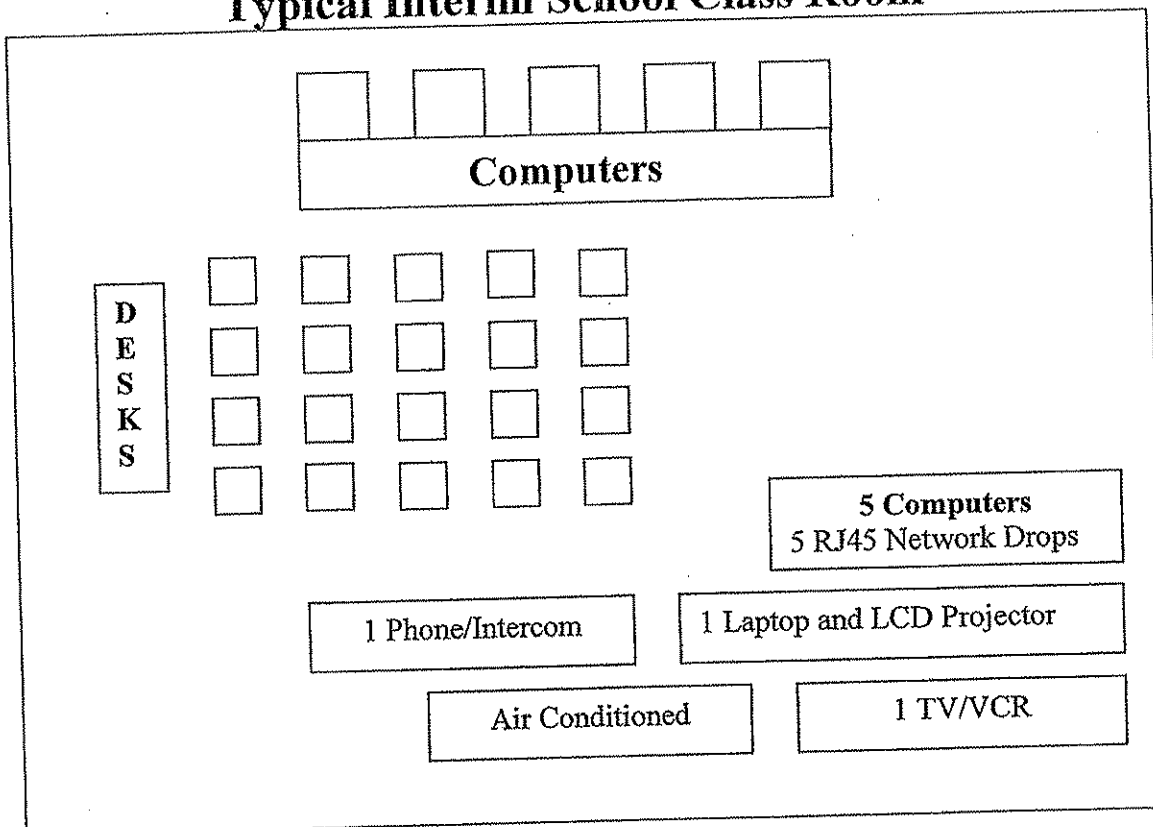

# Parkston School District Network Schematic

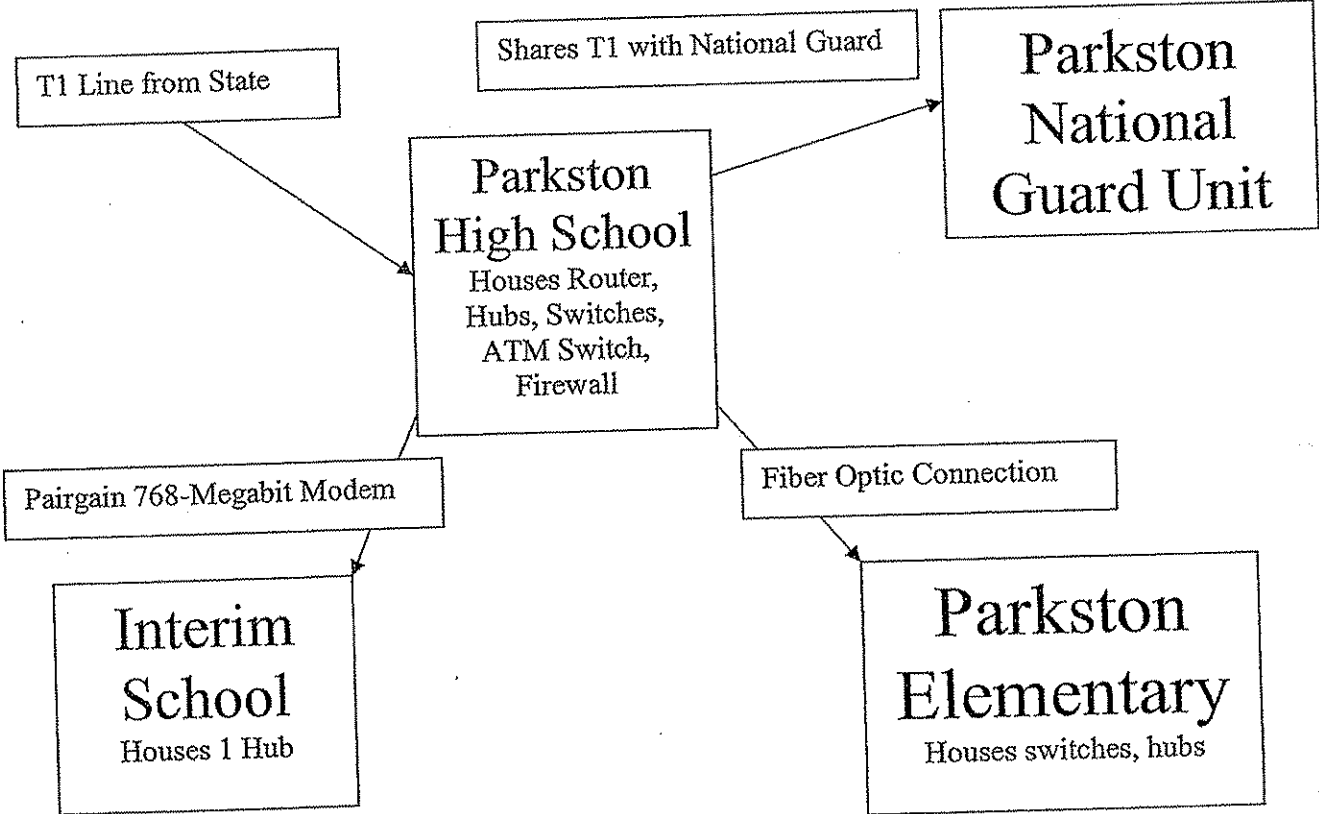

**Old Elm Colony**  
Has own DSL line for Internet Connection.  
(McCook CO-OP)

**New Elm Colony**  
Has own Phone line for Dialup.  
Has USB 56K Modem.  
(Santel CO-OP)

High School Floor Plan

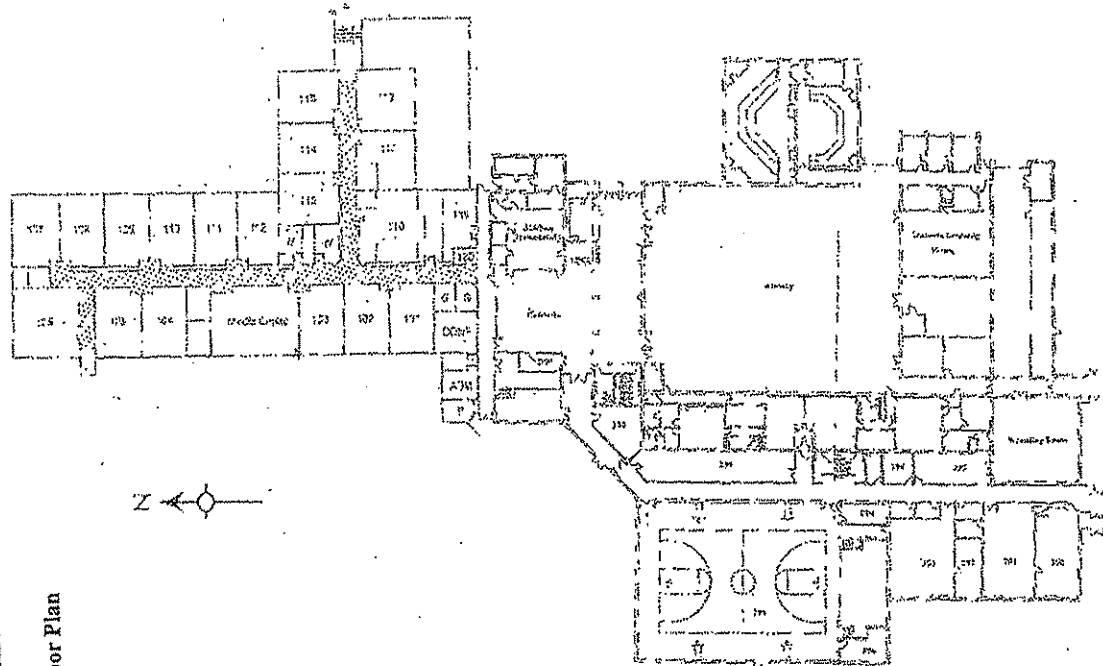

# Interim Floor Plan

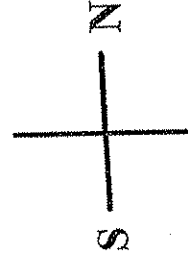
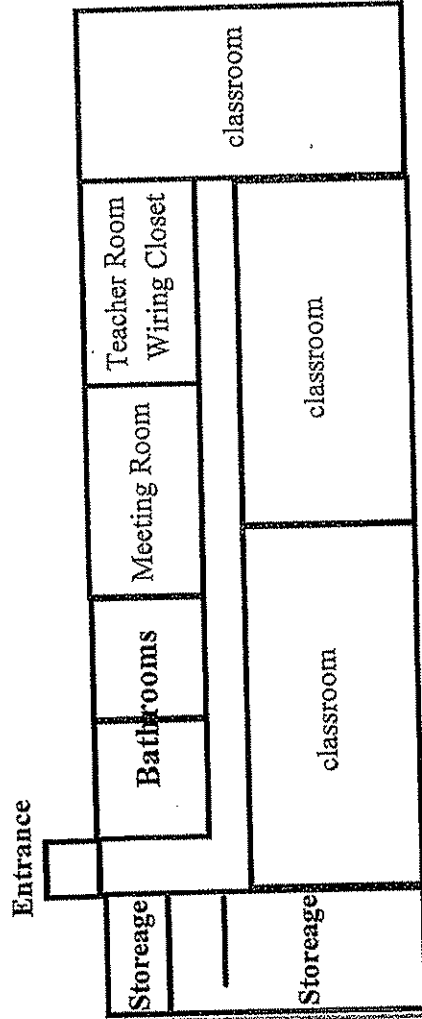

# ***Parkston School District 33-3 Tablet/Laptop Policies and Procedures Handbook***

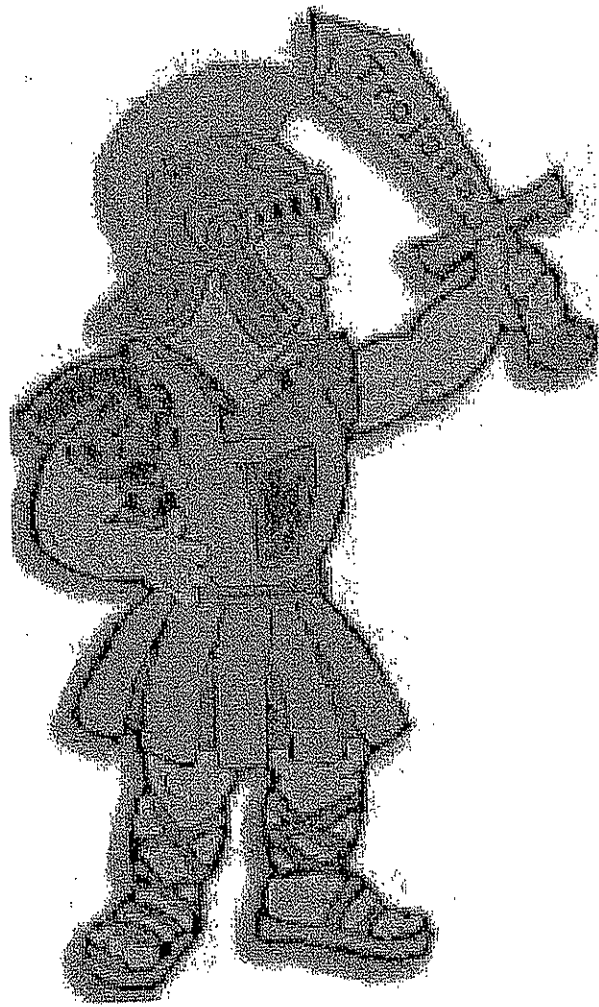

Revised October, 2009

**Parkston School District Tablet/Laptop Program**

The focus of the Learning with Tablet/Laptops Program at the Parkston School District 33-3 is to prepare students for their future, a world of digital technology and information. As we enter the twenty-first century, excellence in education requires that technology be seamlessly integrated throughout the educational program. Increasing access to technology is essential for that future, and the learning tool of these twenty-first century students is the Tablet/Laptop computer. The individual use of Tablet/Laptops is a way to empower students to learn at their full potential and to prepare them for the real world of college and the workplace. Tablet/Laptops encourage students to solve problems and think critically by stimulating analytical thinking. Learning results from the continuous dynamic interaction among students, educators, parents and the extended community. Technology immersion does not diminish the vital role of the teacher. To the contrary, it transforms the teacher from a director of learning to a facilitator of learning. Learning with Tablet/Laptops integrates technology into the curriculum anytime, anyplace.



1. TABLET/LAPTOP SPECIFICATIONS
2. RECEIVING YOUR TABLET/LAPTOP
3. TAKING CARE OF YOUR TABLET/LAPTOP
  - 3.1 General Precautions
  - 3.2 Carrying Tablet/Laptops
  - 3.3 Screen Care
4. USING YOUR TABLET/LAPTOP AT SCHOOL
  - 4.1 Tablet/Laptops Left at Home
  - 4.2 Tablet/Laptop Undergoing Repair
  - 4.3 Charging Your Tablet/Laptops's Battery
  - 4.4 Screensavers
  - 4.5 Sound
  - 4.6 Printing
  - 4.7 Passwords
5. MANAGING YOUR FILES & SAVING YOUR WORK
  - 5.1 Saving to the Home Directory
  - 5.2 Saving data to Removable storage devices
6. SOFTWARE ON TABLET/LAPTOPS
  - 6.1 Originally Installed Software
  - 6.2 Virus Protection
  - 6.3 Additional Software
  - 6.4 Inspection
  - 6.5 Procedure for re-loading software
  - 6.6 Software upgrades
7. ACCEPTABLE USE
  - 7.1 General Guidelines
  - 7.2 Privacy and Safety
  - 7.3 Legal Propriety
  - 7.4 E-mail
  - 7.5 Consequences
8. PROTECTING & STORING YOUR TABLET/LAPTOP COMPUTER
  - 8.1 Tablet/Laptop Identification
  - 8.2 Password Protection
  - 8.3 Storing Your Tablet/Laptop
  - 8.4 Tablet/Laptops Left in Unsupervised Areas
9. REPAIRING OR REPLACING YOUR TABLET/LAPTOP COMPUTER
  - 9.1 Gateway/HP/Dell Warranty
  - 9.2 Accidental Damage Protection
  - 9.3 School District Tablet/Laptop Protection
  - 9.4 Personal Insurance
  - 9.5 Claims
10. TABLET/LAPTOP TECHNICAL SUPPORT
11. TABLET/LAPTOP FAQ'S

The policies, procedures and information within this document apply to all Tablet/Laptops used at Parkston School, including any other device considered by the administration to come under this policy.

Teachers may set additional requirements for computer use in their classroom.

## TABLET/LAPTOP SPECIFICATIONS

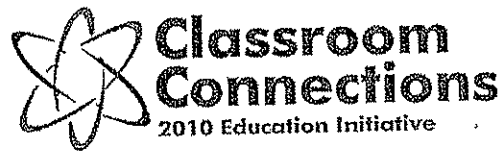

## State of South Dakota "Classroom Connections Project – School Entities"

State of South Dakota Department of Education allows HP to offer the awarded laptop PC from the "Classroom Connections Project" to all "Public Entities" in the State at the same price. The HP Compaq 6930p laptop as bundled below is the approved offering for these education entities:

### HP Compaq 6930p Laptop

Operating System: Microsoft® Windows® XP Professional  
Processor: Intel® Core™ 2 Duo Processor T9400

Memory: 2048MB 800MHz DDR2 SDRAM (1 DIMM)  
Hard Drive: 160 GB 5400rpm SATA  
Screen: 14.1-inch diagonal WXGA anti-glare  
Keyboard: Enhanced dual pointing devices with scroll zone  
Battery: 6Cell (55Whr) Li-ion  
Modem and Network Adapter: 56K v.92,  
Intel WLAN802.11a/b/g/n  
Bluetooth: HP Integrated Module with Wireless Technology  
Video Graphics: ATI Mobility Radeon HD3450 w/256MB of dedicated video memory  
Optical: DVD/CD-RW Combo Drive  
Limited Warranty: 3 year 3/3/0 worldwide warranty

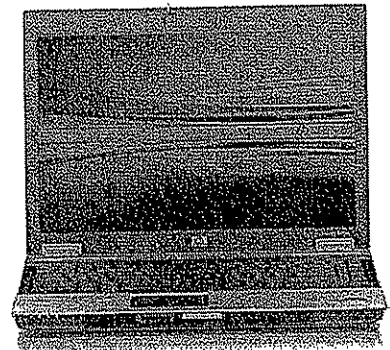

## State of South Dakota – Tablet

The State of South Dakota Department of Education has chosen Gateway/HP/Dell Computers as the selected Tablet/Laptop PC provider for the "Classroom Connections Project". The Gateway/HP/Dell as bundled below is the approved offering for the 1:1 Classroom Connections Year 2 Schools.

### Gateway/HP/Dell

**Operating System:** Microsoft® Windows® XP Tablet/Laptop PC Edition, Microsoft Office Professional Edition (Select Agreement)

**Processor:** Intel® Core™ 2 Duo Processor T5500 (1.66GHz, 667MHz FSB, 2MB L2 Cache)

**Memory:** 1024MB 677MHz DDR2 SDRAM (2-512MB modules)

**Hard Drive:** 40GB 5400rpm Serial ATA hard drive

**Memory Card Reader:** 7-in-1 media card reader

**Optical Drive:** Modular 24x/10x/24x CD-RW / 8x DVD combo

**Screen:** 14.0" WXGA TFT (1280 x 768) with Rotating Hinge for Tablet/Laptop Functionality

**Video:** ATI Mobility™ Radeon® X1400 64MB Graphics featuring Avivo™ display technology

**Digitizer Pens:** Gateway/HP/Dell Executive Stylus Pen w/ Continuous Sensing Technology

**Battery:** Primary 8-cell Lithium ion battery with AC pack and 1 yr. limited battery warranty

**Modem and Network Adapter:** Integrated V.92 56K modem, Integrated Intel® 10/100/1000 Ethernet Adapter, Integrated Intel® 802.11a/b/g wireless networking card

**Extended Service Plan Including Limited Warranty:** 3 year parts, labor, Authorized Service Provider (ASP) service, 3 year limited technical support

**Accidental Damage Protection:** Three (3) years accidental damage protection

**Protective Sleeve:** Infocase Crush Resistant Sleeve (with strap)

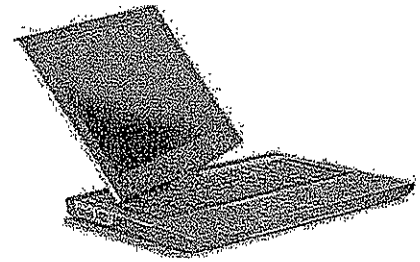

## 2. RECEIVING YOUR TABLET/LAPTOP

To receive a Tablet/Laptop computer, students must:

1. Attend the Tablet/Laptop orientation with a parent or legal guardian.
2. Submit Tablet/Laptop Computer Protection form.
3. Submit Student Agreement for Tablet/Laptop Use form.

Tablet/Laptops will be collected at the end of each school year for maintenance, cleaning and software installations. Students will retain their original Tablet/Laptop each year while enrolled at PHS.

## 3. TAKING CARE OF YOUR TABLET/LAPTOP

Students are responsible for the general care of the Tablet/Laptop they have been issued by the school. Tablet/Laptops that are broken or fail to work properly must be taken to the technology Help Desk located in Room 120. If you have any questions, you may e-mail Mr. Kinneberg at [Tony.Kinneberg@k12.sd.us](mailto:Tony.Kinneberg@k12.sd.us).

### 3.1 General Precautions

- No food or drink is allowed next to your Tablet/Laptop while it is in use.
- Insert and remove cords, cables and removable storage devices carefully.
- Students should never carry their Tablet/Laptops while the screen is open, unless directed to do so by a teacher.
- Shut down the computer when not in use to conserve battery life.
- Stickers, drawings, or permanent markers may not be used on the computer.
- Do not vandalize the computers or any other school property.
- Tablet/Laptops must never be left in a car or any unsupervised area.
- Students are responsible for keeping their Tablet/Laptop's battery charged for school each day.

### 3.2 Carrying Tablet/Laptops

The protective cases provided with Tablet/Laptops have sufficient padding to protect the Tablet/Laptop from normal treatment and provide a suitable means for carrying the computer within the school. The guidelines below should be followed:

- Tablet/Laptops should always be carried within the protective case provided by PHS.
- Some carrying cases can hold other objects (such as folders and workbooks), but these must be kept to a minimum to avoid placing too much pressure and weight on the Tablet/Laptop.
- The Tablet/Laptop must be turned off before placing it in the carrying case. Carrying Tablet/Laptops in the carrying case between class periods may be done while Tablet/Laptop cover is closed and Tablet/Laptop is hibernating.

### 3.3 Screen Care

The Tablet/Laptop screens can be damaged if subjected to rough treatment. The screens are particularly sensitive to damage from excessive pressure on the screen.

- Do not lean on the top of the Tablet/Laptop when it is closed.
- Do not place anything near the Tablet/Laptop that could put pressure on the screen.
- Do not place anything in the carrying case that will press against the cover.
- Do not poke the screen.
- Do not place anything on the keyboard before closing the lid (e.g. pens, pencils, or disks).  
Clean the screen with a soft, dry cloth or anti-static cloth.

## 4. USING YOUR TABLET/LAPTOP AT SCHOOL

Tablet/Laptops are intended for use at school each day. In addition to teacher expectations for Tablet/Laptop use, school messages, announcements, calendars and schedules will be accessed using the Tablet/Laptop computer. Students must be responsible to bring their Tablet/Laptop to all classes, unless specifically advised not to do so by their teacher. Repeat violations of this policy will result in disciplinary action.

#### 4.1 Tablet/Laptops Left at Home

If students leave their Tablet/Laptop at home, they may phone parents/guardians to bring them to school. Students without a Tablet/Laptop will use a computer in each classroom as they are available.

#### 4.2 Tablet/Laptop Undergoing Repair

Students will use computers in the classrooms while their Tablet/Laptop is undergoing repair. Loaner Tablet/Laptops may be issued for use at the administrator's discretion.

#### 4.3 Charging Your Tablet/Laptop's Battery

Tablet/Laptops must be brought to school each day in a fully charged condition. Power cords must stay with the computer at all times.

#### 4.4 Screensavers

Screen savers and backgrounds must be appropriate. Presence of guns, weapons, pornographic materials, inappropriate language, alcohol, drugs, gang related symbols or pictures, or other items deemed inappropriate by administration will result in disciplinary actions.

#### 4.5 Sound

Sound must be muted or the use of head sets must be used at all times unless permission is obtained from the teacher for instructional purposes.

#### 4.6 Printing

Students may use printers in classrooms, the library, and computer labs with teachers' permission during class or breaks. All printing should be limited to educational purposes.

#### 4.7 Passwords

Use of passwords on screensavers or hard drive is forbidden. Use of passwords may result in disciplinary action including but not limited to cost of replacement hardware and/or software.

### 5. MANAGING YOUR FILES & SAVING YOUR WORK

#### 5.1 Saving to the Home Directory

Each student will have a user account and **Home Directory** (My Documents) on the school network with ample space to save any school-related work. Additional folders in the **Home Directory** may be created or added by the student. All student work should be stored in their **Home Directory**.

Only files stored in the **Home Directory** will be automatically backed up and saved. Student work saved to a different location on the computer will not be automatically saved to the school server. Students should be aware that the **Home Directory** is not accessible outside of school.

Students should create a separate folder on their desktop for non-backed-up files, including but not limited to music, mp3, Windows Movie Maker, Photo Story and other large projects.

#### 5.2 Saving data to Removable storage devices

Students should also backup all of their work at least once a week using removable file storage. Removable memory cards, flash drives, or recordable CDs may be purchased.

It is the student's responsibility to ensure that work is not lost due to mechanical failure or accidental deletion. Computer malfunctions are not an acceptable excuse for not submitting work.

## 6. SOFTWARE ON TABLET/LAPTOPS

### 6.1 Originally Installed Software

The software originally installed by the Parkston School District must remain on the Tablet/Laptop in usable condition and be easily accessible at all times.

The Tablet/Laptop is supplied with Microsoft® Windows® XP Tablet/Laptop PC Edition operating system and with additional software. Licensed software provided with all new Tablet/Laptops includes but is not limited to:

- Microsoft Office Professional Edition including Word, Excel, Access, FrontPage,
- PowerPoint & Publisher
- Symantec Antivirus
- Windows Media Player
- Windows Movie Maker
- Adobe Reader
- Photo story for Windows
- Notebook Software

From time to time the school may add software applications for use in a particular course. The licenses for this software require that the software be deleted from Tablet/Laptops at the completion of the course. Periodic checks of Tablet/Laptops will be made to ensure that students have deleted software that is no longer required in class and that the school has not exceeded its licenses.

### 6.2 Virus Protection

The Tablet/Laptop has anti-virus protection software. This software will scan the hard drive and other drives on boot up for known viruses. The virus software will be upgraded from the network. The school's storage server is also installed with virus protection software and hardware.

### 6.3 Additional Software

It is the responsibility of individual students to be aware of additional software programs and files loaded onto their Tablet/Laptop, which are required for classes and/or school activities.

Any additional software must be appropriate for the school environment.

Each student is responsible for ensuring that only licensed software is loaded onto his or her computers.

Violent games and computer images containing obscene or pornographic material are banned.

### 6.4 Inspection

Students may be selected at random to provide their Tablet/Laptop for inspection.

### 6.5 Procedure for re-loading software

If technical difficulties occur or illegal software is discovered, all files and the hard drive will be re-formatted. Only authorized software will be installed. The school does not accept responsibility for the loss of any software deleted due to a re-format and re-image.

### 6.6 Software upgrades

Upgrade versions of licensed software are available from time to time. Students will be instructed to upgrade their software from the school's network periodically.

## 7. ACCEPTABLE USE

### 7.1 General Guidelines

- (1) Students will have access to all available forms of electronic media and communication approved by administration, which is in support of education and research and in support of the educational goals and objectives of the Parkston School District.
- (2) Students are responsible for ethical use of the technology resources of the Parkston School district.
- (3) Access to the Parkston School District technology resources is a privilege and not a right. Each employee, student and/or parent will be required to follow the Acceptable Use Policy.
- (4) Transmission of any material that is in violation of any federal or state law is prohibited. This includes, but is not limited to the following: confidential information, copyrighted material, music downloads, threatening or obscene material, and computer viruses.
- (5) Any attempt to alter data, the configuration of a computer, or the files of another user, without the consent of the individual, school administrator, or technology administrator, will be considered an act of vandalism and subject to disciplinary action.

### 7.2 Privacy and Safety

Do not go into chat rooms or send chain letters without permission.

Do not open, use, or change computer files that do not belong to you.

Do not reveal your full name, phone number, home address, social security number, credit card numbers, password or passwords of other people.

Remember that storage is not guaranteed to be private or confidential.

If you inadvertently access a web site that contains obscene, pornographic or otherwise offensive material, notify a teacher immediately so that such sites can be blocked from further access.

This is not merely a request; it is a responsibility.

### 7.3 Legal Propriety

Students must comply with trademark and copyright laws and all license agreements. Ignorance of the law is not immunity. If you are unsure, ask a teacher or parent.

Plagiarism is a violation. Give credit to all sources used, whether quoted or summarized. This includes all forms of media on the Internet, such as graphics, movies, music, and text.

Use or possession of hacking software is strictly prohibited and violators will be subject to disciplinary action.  
Violation of applicable state or federal law, including the South Dakota Penal Code, Computer Crimes, will result in criminal prosecution or disciplinary action by the District.

#### 7.4 E-mail

Always use appropriate language.  
Do not transmit language/material that is profane, obscene, abusive, or offensive to others.  
Do not send mass e-mails, chain letters or spam.  
Students should maintain high integrity with regard to email content.  
No private chatting during class without permission.  
E-mail is subject to inspection by the school.

#### 7.5 Consequences

The student in whose name a system account and/or computer hardware is issued will be responsible at all times for its appropriate use. Non-compliance with the policies of the Tablet/Laptop Handbook or Acceptable Use Policy will result in disciplinary action.

Electronic mail, network usage, and all stored files ***shall not be considered confidential and may be monitored at any time by designated District staff to ensure appropriate use.*** The District cooperates fully with local, state or federal officials in any investigation concerning or relating to violations of computer crime laws. The South Dakota Open Records Act governs contents of e-mail and network communications; proper authorities will be given access to their content.

## 8. PROTECTING & STORING YOUR TABLET/LAPTOP COMPUTER

### 8.1 Tablet/Laptop Identification

Student Tablet/Laptops will be labeled in the manner specified by the school. Tablet/Laptops can be identified in the following ways:

- Record of serial number
- Individual User account name and password

### 8.2 Password Protection

Students are expected to password protect their Tablet/Laptops by using their Windows Log-in and password, and keeping that password confidential.

### 8.3 Storing Your Tablet/Laptop

When students are not using their Tablet/Laptops, they should be stored in their lockers. Nothing should be placed on top of the Tablet/Laptop. Students are encouraged to take their Tablet/Laptops home every day after school. Tablet/Laptops should not be stored in a student's vehicle at school or at home. Extreme temperatures will damage your computer.



#### 8.4 Tablet/Laptops Left in Unsupervised Areas

Under no circumstances should Tablet/Laptops be left in unsupervised areas. Unsupervised areas include the school grounds and campus, the cafeteria, computer lab, locker rooms, library, unlocked classrooms, dressing rooms and hallways. Any computer left in these areas is in danger of being stolen.

Unsupervised Tablet/Laptops will be confiscated by staff and taken to the Principals' Office. Disciplinary action may be taken for leaving your Tablet/Laptop in an unsupervised location. First offense will be a warning, second offense ½ hour of detention, third offense 1 hour of detention, fourth offense Saturday school, and fifth offense in school suspension. If this happens more than five times, it will be loss of the privilege of taking the Tablet/Laptop home.

### 9. REPAIRING OR REPLACING YOUR TABLET/LAPTOP COMPUTER

#### 9.1 Gateway/HP/Dell Warranty

This coverage is purchased by the Parkston School District as part of the purchase price of the equipment. Gateway/HP/Dell warrants the Tablet/Laptops from defects in materials and workmanship. This limited warranty covers normal use mechanical breakdown or faulty construction and will provide replacement parts necessary to repair the Tablet/Laptop or Tablet/Laptop replacement. The Gateway/HP/Dell warranty does not warrant against damage caused by misuse, abuse, accidents or computer viruses. Please report all Tablet/Laptop problems to the technology Help Desk located in the study hall.

#### 9.2 Accidental Damage Protection

The Parkston School District has purchased through Gateway/HP/Dell/HP/Dell coverage to protect the Tablet/Laptops against accidental damage such as: liquid spills, accidental drops, power surges, and natural disasters. This coverage does not provide for damage caused by fire, theft, loss, misuse, intentional or frequent damage or cosmetic damage. Gateway/HP/Dell/HP/Dell will assess the Tablet/Laptop damage and repair or replace the machine at not cost if the damage is determined to be accidental, infrequent, and within the protection guidelines. PHS will service repairs and replacements for defective parts and acts of accidental damage. Please report all Tablet/Laptop problems to the technology Help Desk.

#### 9.3 School District Tablet/Laptop Protection

Parkston School District protection is an optional insurance available to cover Tablet/Laptop replacement in the event of theft, loss, or accidental damage by fire. This protection for Tablet/Laptop computers is \$25.00 annually for each student, with a maximum cost of \$50.00 per family. This coverage includes a \$200.00 additional charge per claim.

#### 9.4 Personal Insurance

Students or parents may wish to carry their own personal insurance to protect the Tablet/Laptop in cases of theft, loss, or accidental damage by fire. Please consult with your insurance agent for details about your personal coverage of the Tablet/Laptop computer.

### 9.5 Claims

All insurance claims must be reported to the Technology Help Desk. Students or parents must file a police or fire report and bring a copy of the report to the principal's office before a Tablet/Laptop can be repaired or replaced with School District.

Fraudulent reporting of theft, loss, or accidental damage by fire will be turned over to the police and insurance company for prosecution.

The District will work with the Parkston Police Department to alert pawnshops and police departments in the area to be aware of this District-owned equipment.

## 10. TABLET/LAPTOP TECHNICAL SUPPORT

The Technology Help Desk is located in the Room 120 and coordinates the repair work for Tablet/Laptops. Services provided may include but are not limited to the following:

- Hardware maintenance and repairs
- Password identification
- User account support
- Operating system or software configuration support
- Application information
- Re-imaging hard drives
- Updates and software installations
- Coordination of warranty repairs
- Distribution of loaner Tablet/Laptops and batteries

## 11. TABLET/LAPTOP FAQ'S

### **1. Can I use the Tablet/Laptop computer and software throughout my career at PHS?**

Yes. While the rapid pace of computer technology guarantees that more advanced units will be available before you graduate, your unit will be powerful enough for your classroom work throughout your career at PHS. The available software will be usable in upper level as well as entry-level course work. Of course, just as upper level courses require different textbooks, you may need additional software as you move through the curriculum.

### **2. What if I already have another model or brand of Tablet/Laptop computer?**

*You will be required to use the school district issued Tablet/Laptop for school purposes. This is necessary to ensure that you have a computer that gives you network capability and the ability to run the software that you will need in your courses. The Parkston School District is also limited to provide maintenance service or assistance for only the Tablet/Laptop provided. For these reasons, other Tablet/Laptop computers will not be used on the Parkston School District network at school.*

### 3. Can I have my Tablet/Laptop computer this summer?

No. All Tablet/Laptops will be collected at the end of the school year for general maintenance, cleaning, and software installation purposes. Students will receive their Tablet/Laptops again at their orientation session in the fall to ensure that everyone receives complete information about the computer, including its warranty, insurance coverage, software usage and PHS's policy regarding the ethical use of computers.

### 4. Where do I find a service technician?

Take your Tablet/Laptop to the Help Desk in the Room 120.

### 5. What about insurance against theft or breakage through carelessness?

Your Tablet/Laptop computer is very portable and very valuable, making it an attractive target for thieves. The best insurance is to take care of your Tablet/Laptop. Do not leave your Tablet/Laptop in the building, classroom, or car unattended. Always know where your Tablet/Laptop is! Above all, take your computer home each night.

### 6. Does PHS provide maintenance on my Tablet/Laptop computer?

Yes. The Technical Services Help Desk staff will coordinate maintenance for students. The Technology Help Desk is located in Room 120 and coordinates the repair work for Tablet/Laptops. Students are expected to keep the Tablet/Laptops in good condition. Failure to do so may result in fines as specified below:

ITEM	COST	ESTIMATE REPAIR TIME
Broken Latch	\$10	7 Days
Damaged Keyboard	\$10	7 Days
Broken Screen	\$30	7-14 Days
Dropped/Broken Tablet/Laptop	\$50	7-14 Days
Stolen Tablet/Laptop	\$200	7-14 Days
Re-image Hard Drive	\$10	1 Day
Damaged/Lost Cord	\$35	7 Days

- Pricing above is based on the 2007-08 school year and is subject to change.

- Pricing above is for accidental damage. Deliberate damage will result in disciplinary action as well as a fine.

**7. What will I do without a computer in my classes if my Tablet/Laptop unit is being repaired or while I am replacing it if it is lost or stolen?**

Students will use computers located in the classrooms while his/her Tablet/Laptop is being repaired/replaced. Parkston School will stock a limited number of Tablet/Laptop computers that can be loaned out on a case by case basis. You will be able to apply for a loaner unit at the Help Desk in Room 120, the same area where you will go for service on your Tablet/Laptop computer. *If you are in possession of a loaner, treat it as if it were your own computer. You will be responsible for any damage to the unit or for its loss.*

**8. If I purchase software in addition to the available software provided through PHS, will the Technical Help Desk staff load it for me?**

Yes, if the district approves it.

**9. Do I need a printer?**

You need not own one since printers are located near classrooms, in the library, and in the study hall. If you want to connect to a printer at home with the school Tablet/Laptop, you will need to visit the technology Help Desk and ask to have your printer software installed.

**10. Will I need to buy a modem?**

No. A modem is built into the Tablet/Laptop.

**11. How do I connect to the Internet at home?**

You will need to talk to your Internet Service Provider to purchase Internet access at home. Each company will provide specific instructions for accessing the Internet with your Tablet/Laptop. Further help may be received through the Help Desk.

**12. Will there be facilities to back up the files I create on my Tablet/Laptop?**

Yes. When you save your documents to the My Documents folder, your files are automatically saved to your H: drive when you connect to the school network. You are also encouraged to save your documents to a Flash Drive or other portable storage device.

**13. What if I want to add options to my Tablet/Laptop later?**

Only the Parkston School District is authorized to add options and upgrades to your Tablet/Laptop computer.

**14. What if I want to run another operating system on my Tablet/Laptop?**

Only the operating system chosen by the Parkston School District will be authorized to run on a student-issued Tablet/Laptop computer.

**15. Will I be given a new battery if mine goes bad?**

The manufacturer for defects will replace the Tablet/Laptop battery. You will be responsible for charging your battery and proper battery maintenance.

**16. What has the school done to help prevent students from going to inappropriate sites?**

We have a software product, which is designed to help monitor all Internet sites that students attempt to access. This software blocks inappropriate sites and also logs a history of every site that each user opens. All students who attempt to find inappropriate sites will be directed to the Principal's Office for possible disciplinary action.

**17. Are Student Tablet/Laptops subject to school "snooping"; what if they bring their Tablet/Laptop in for repairs and "objectionable data" is detected?**

Inappropriate material on Tablet/Laptops should be reported to the classroom teacher, the principal, or the Help Desk immediately upon identification. Students who have "objectionable data" on their Tablet/Laptop, but have failed or chosen not to report it, will be referred to the Principal's Office.

**18. If the accessories to my Tablet/Laptop are lost or stolen, how much will it cost to replace them?**

In the event that Tablet/Laptop accessories are lost or stolen, you should report the items to the Help Desk. The cost to replace specific accessories is listed below:

- a) AC adapter & power cord: \$30
- b) Battery: \$130
- c) Stylus Pen: \$50
- d) Protective Sleeve: \$27

\*Shipping and handling costs will be added to each replacement item.

## TABLET/LAPTOP COMPUTER PROTECTION AGREEMENT

The Parkston School District recognizes that with the implementation of the Tablet/Laptop initiative there is a need to protect the investment by both the District and the Student/Parent. The following outlines the various areas of protection: warranty, accidental damage protection and insurance.

**Laptop/Tablet WARRANTY:** This coverage is purchased by the Parkston School District as part of the purchase price of the equipment. Gateway/HP/Dell/HP/Dell warrants the Tablet/Laptops from defects in materials and workmanship. This limited warranty covers normal use, mechanical breakdown or faulty construction and will provide replacement parts necessary to repair the Tablet/Laptop or Tablet/Laptop replacement. The Gateway/HP/Dell/HP/Dell warranty does not warrant against damage caused by misuse, abuse, accidents or computer viruses.

**ACCIDENTAL DAMAGE PROTECTION:** The Parkston School District has purchased through Gateway/HP/Dell/HP/Dell coverage to protect the Tablet/Laptops against accidental damage such as: liquid spills, accidental drops, power surges, and natural disasters. This coverage does not provide for damage caused by fire, theft, loss, misuse, intentional or frequent damage or cosmetic damage. Gateway/HP/Dell will assess the Tablet/Laptop damage and repair or replace the machine at no cost if the damage is determined to be accidental, infrequent, and within the protection guidelines.

**INSURANCE FOR THEFT, LOSS OR FIRE:** Tablet/Laptops that are stolen, lost or damaged by fire are not covered by the Gateway/HP/Dell/HP/Dell Warranty or the Accidental Damage Protection outlined above. Following are the three options that are available for these types of losses, and the Student/Parent must commit to one by checking the appropriate box.

- No Insurance - You agree to pay for the replacement of the Tablet/Laptop at a cost not to exceed \$1,300.00 should the Tablet/Laptop be stolen, lost or damaged by fire.
- Personal Insurance -You will cover the Tablet/Laptop under your own insurance policy and in the case of a theft, loss or damage by fire, you agree to pay the District the amount received from your insurance company plus any additional amount needed to cover the Tablet/Laptop replacement not to exceed \$1,300.00.
- School District -You choose to pay the school district an annual protection payment for coverage of theft, loss or damage by fire in the amount of \$25.00 or \$50.00 for family coverage when there are two or more children in high school using Tablet/Laptop computers. The \$25.00 payment is non-refundable. This protection coverage has a \$200.00 additional charge per occurrence. This annual coverage begins upon receipt of the payment and ends at the conclusion of each school year.

(over)



**ADDITIONAL INFORMATION:** In cases of theft, vandalism and other criminal acts, a police report, or in the case of fire, a fire report **MUST be filed by the student or parent** for the protection coverage to take place. A copy of the police/fire report must be provided to the principal's office. The \$200.00 additional charge is the responsibility of the student/parent and must be paid before the Tablet/Laptop can be repaired or replaced.

**INTENTIONAL DAMAGE:** Students/Parents are responsible for full payment of intentional damages to Tablet/Laptops. Warranty, Accidental Damage Protection, or School District Tablet/Laptop Protection **DOES NOT** cover intentional damage of the Tablet/Laptops.

Student Name: \_\_\_\_\_ (Please Print)

Student Signature: \_\_\_\_\_ Date: \_\_\_\_\_

Parent Signature: \_\_\_\_\_ Date: \_\_\_\_\_

## **STUDENT HANDBOOK TABLE OF CONTENTS**

Page	
2	Mission Statement, Philosophy of Education
3	Non-discrimination Statement, Academic and General Policies
5	Distance Learning Policy, Add/Drop Policy
6	Computer Checkout and Damage Info., Classification of Students, Requirements for Graduation
8	South Dakota Opportunity Scholarship
9	Grades and Honor Roll
10	Care of Textbooks, Co-Curricular Eligibility Policy (Parkston)
11	Junior High Eligibility, SDHSAA Eligibility Policy
12	Student Conduct at Athletic Activities as Set by SDHSAA
13	List of Activities
14	Attendance
16	Study Halls, Media Center
17	Hallway Rules, Cheating, Telephone, School Dances and Parties, Cafeteria – Lunch Period, Fire Drills and Tornado Drills
18	Lockers, Insurance, Church Night, No School Announcements, Printed Material, Student Appearance and Conduct
21	Student Discipline – Bully Prevention
22	Transportation and Parking
24	Prohibited Materials
25	Damage to School Property, Disruption of School, Discipline
27	Discipline Grid
28	Class Dues, Bicycles, Visitors, School Phone Numbers, Withdrawal from School
29	Clubs and Organizations, Hat Policy, Laser Light Policy, Restrooms Office Etiquette, Report Cards, Parent-Teacher Conferences, Disciplinary Reports and Deficiency Reports, Graduation
30	Communicable Disease Guidelines
31	Student Grievance
32	Parent Grievance
33	Parkston School District Medication Policy
35	Parkston School District Request and Authorization for Medication/Treatment
36	Civil and Legal Rights and Responsibilities, Co-curricular and extra-curricular Offerings and Lettering Guidelines
37	National Honor Society Selection Process
39	Senior Privileges
40	FERPA Fact Sheet – Family Educational Rights and Privacy Act
41	Parkston School District Guidelines for Extra-curricular participation
43	Internet and electronic Mail acceptable use Policy

## **STUDENT HANDBOOK 2007-08**

### **MISSION STATEMENT – DISTRICT #33-3**

Preface: To empower all to succeed in a changing world.

Our commission to students is to develop the intellectual, physical, emotional health, the ethical values, vocational competence, the appreciation for family and civic roles, and appreciation of the democratic processes to the best of their capabilities. We are committed to develop a feeling of positive worth in young people, which will allow them to maintain a zeal for continuous learning and self-improvement. Our aim being to provide quality education and recognizing a quality staff is the key to quality education. We are dedicated to the development of skills and full human potential of all staff members. We want the home and the schools to work closely together to strengthen the educational process.

### **PHILOSOPHY OF EDUCATION**

The Board of Education of the Parkston School District #33-3 believes that each individual should be accepted into the educational program as he/she is, that he/she shall be provided with a stimulating environment and opportunities for learning and to become life-long learners.

#### **WE BELIEVE**

- All students can learn, achieve and succeed when given the correct level and time for learning
- Every student has the right and responsibility to learn basic and life skills
- Education, being a valuable asset, is a responsibility shared by the student, school, home and community
- Parental and community participation is vital to student success
- A quality school system enhances the quality of the community
- That successful learning occurs when adults, peers and students all have high expectations for success
- Changes can create the opportunity to improve

We believe that we should focus and organize all of the school's programs and instructional efforts around clearly defined expectations that we want students to demonstrate when they leave school.

#### **WE BELIEVE STUDENTS SHOULD BE ABLE TO:**

- Be proficient in listening, speaking, reading, writing, mathematics, and the use of technology.
- Demonstrate knowledge of the arts and sciences.
- Demonstrate a healthy self-esteem.
- Select and use thinking skills individually and in groups to solve problems and to make decisions.
- Find, evaluate and use information.
- Be self-directed learning who are adaptable to change.
- Demonstrate a positive work ethic.
- Recognize and care for their environment, their heritage and the rights, opinions and property of others.

As a result of these beliefs, students should be able to apply what they learn, effectively make decisions with that knowledge, and be responsible for their actions.

## **NONDISCRIMINATION STATEMENT**

The Parkston School District #33-3 does not discriminate in its employment policies and practices, or in its educational program on the basis of race, color, creed, religion, age, sex, marital status, disability or national origin.

Inquiries concerning the application of Title IX, Section 504, Affirmative Action, and the Americans with Disabilities Act may be referred to Mr. Shayne McIntosh, Superintendent of Schools, (Telephone Number 928-3368), 102C S. Chapman Drive, Parkston, SD 57366, or to the Regional Director, Department of Education, Office of Civil Rights, 1244 Speer Blvd. Suite 310, Denver, Colorado, 80202-3582. Phone (303) 844-5695: TDD (303) 844-3417.

## **ACADEMIC AND GENERAL POLICIES**

In the spring students register for the classes they wish to take during the following the year. This is necessary so that a schedule of classes and class lists can be prepared during the summer by the principal. Proper registration is very important and careful consideration should be given by the parent and student so that graduation requirements can be met. A student can have only one study hall over the course of 2 days. Following is a list of courses that are offered to the students at each grade level.

### **Seniors**

Accounting I  
Accounting II  
Advanced Foods  
Algebra II  
Art I  
Band  
Biology II  
Business Law  
CADKEY  
Calculus  
Career Ed/Internship  
Ceramics  
Chemistry I  
Child Development  
Chorus  
Commercial Art  
Communication Tech  
Composition and Grammar III  
Computer II  
Computer III  
Construction Tech  
Consumer Math  
Drama  
Drawing  
Economics  
English Literature \*\*  
Family Living  
Geometry  
Government \*\*  
Graphic Art  
Human A&P  
Industrial Tech III  
Journalism I  
Journalism II

### **Juniors**

Accounting I  
Algebra I  
Algebra II  
American History\*\*  
American Literature\*\*  
Art I  
Band  
Biology II  
Business Law  
CADKEY  
Career Ed/Internship  
Ceramics  
Chemistry I  
Child Development  
Chorus  
Commercial Art  
Communication Tech  
Composition and Grammar III  
Computer II  
Computer III  
Construction Tech  
Consumer Math  
Drama  
Drawing  
Economics  
Family Living  
General Business  
Geometry  
Graphic Art  
Industrial Tech III  
International Relations  
Journalism I  
Journalism II  
Life Skills

Life Skills  
 Manufacturing Tech  
 Music Appreciation  
 Novels  
 Occupational Foods  
 Occupational Child Care  
 Painting  
 Personal Finance  
 Physical Education  
 Physics  
 Print Making  
 Psychology  
 Research and Writing  
 Sculpture  
 Short Stories  
 Sociology  
 Spanish I  
 Spanish II  
 Tech Ed (Modules)  
 Technical Business Writing  
 Transportation Tech  
 Trigonometry  
 Welding  
 World History

**\*\* Required Courses**

**Sophomores**

Algebra I  
 Algebra II  
 Art I  
 Band  
 Biology I\*\*  
 Ceramics  
 Child Development  
 Chorus  
 Commercial Art  
 Communication Tech  
 Composition and Grammar II\*\*  
 Computer II  
 Construction Tech  
 Consumer Math  
 Drama  
 Drawing  
 Family Living  
 General Business  
 Geometry  
 Graphic Art  
 International Relations  
 Journalism I  
 Life Skills  
 Manufacturing Tech  
 Music Appreciation  
 Painting  
 Print Making  
 Sculpture  
 South Dakota History

Manufacturing Tech  
 Music Appreciation  
 Occupational Child Care  
 Occupational Foods  
 Painting  
 Physical Education  
 Print Making  
 Psychology  
 Sculpture  
 Sociology  
 South Dakota History  
 Spanish I  
 Spanish II  
 Tech Ed (Modules)  
 Technical Business Writing  
 Transportation Tech  
 Trigonometry

**\*\* Required Courses**

**Freshmen**

Algebra I  
 Art I  
 Band  
 Ceramics  
 Chorus  
 Commercial Art  
 Communication Tech  
 Composition and Grammar I\*\*  
 Computer I\*\*  
 Construction Tech  
 Drama  
 Drawing  
 General Business  
 Graphic Art  
 Life Skills  
 Manufacturing Tech  
 Music Appreciation  
 Painting  
 Physical Education\*\*  
 Physical Science\*\*  
 Pre-Algebra  
 Print Making  
 Sculpture  
 South Dakota History  
 Spanish I  
 Speech\*\*  
 Transportation Tech  
 World Geography\*\*

Spanish I  
Spanish II  
Transportation Tech  
World History\*\*  
World Literature\*\*

**\*\* Required**

**\*\* Required**

All students are required to pursue a minimum of 5 ½ credits in a given year. Also all students must be taking at least 6 classes in a given semester. The maximum number of courses shall be seven unless approved by the administration and parents. Then the maximum may be greater than seven.

**POLICY ON DISTANCE LEARNING COURSES**

All distance education programs and courses will be consistent with the District instructional goals and aligned with South Dakota's academic standards, curriculum framework and assessment.

Students seeking to take a course through distance education must meet with the guidance counselor and/or principal before registering for a distance learning course. All registrations will be done by the Parkston School District. Courses will be accepted from the Virtual High School of South Dakota, Dual Credit courses from in-state institutions and from out of state institutions on a case by case basis. The courses that will be made available to the students are the courses that Parkston High School does not offer, or in extreme situations, due to scheduling conflicts, a course that is offered at Parkston High School can be taken from the Virtual High School. If a student has to take a course for credit retrieval and the student elects to take the course from the Virtual High School, the student will not be eligible for senior privileges. The courses that are taken for dual credit may not be accepted by all colleges and universities, so it is the responsibility of the student to check to see if the credits are accepted by the college or university they plan on attending.

Courses that will be put on the Parkston High School transcript will be those courses that come from the Virtual High School of South Dakota and any course that is labeled as dual credit from a state institution. Payment for the course and the textbooks, will be paid for by the district as long as the course is put on the high school transcript.

AP courses that are offered through the Virtual High School will be paid for by the school district as long as the student maintains a C average. Once the grade drops below a C average the cost of the course will be the responsibility of the student. It is also the responsibility of the student to pay for the AP exam if the student elects to take the exam.

High School students may earn a maximum of four units of academic credit unless otherwise specified in the student's Individualized Education Plan to be applied toward graduation requirements by completing virtual/online courses accredited by the South Dakota State Board of Education.

All students must meet with guidance counselor and principal to confirm that the student possesses the maturity level needed to function effectively in an online learning environment.

Students are required to carry 6 courses each semester. Within that 6, classes taken from the Virtual High School and any dual credit course will count. A student taking a course from any other institution will be taken during that student's study hall. If a student wants to take two courses from another institution, it will be on a case by case basis.

**ADD/DROP POLICY**

All students shall have the opportunity to add or drop any course up to three days into the course. No adds or drops will be allowed after that time. Withdrawal from a given course is prohibited until the end of the semester. At that time the student may withdraw from a course and still be granted their earned grade and credit.

## **COMPUTER TABLET CHECKOUT AND DAMAGE COSTS**

Starting in the school year 2007-2008, the Parkston School District joined the One-to-One Initiative which provides a laptop computer for each student in grades 9-12. The students will be responsible for the welfare of the computer and the carrying case that the computer is carried in. Listed below are the possible fines for damage that the students could be assessed. These dollar figures will change as the cost of replacing certain parts change.

- Stylus (Missing or damaged) – Replacement cost \$39.00
- Plug adapter (Missing or damaged) – Replacement cost \$29.00
- Damage to bag (damaged, handles gone, zipper bad shape) – Replacement cost \$33.00
- Scratches on outside (severe damage to lid, CD, Screen) – Replacement Cost \$25.00 and up
- Blue Cloth (Missing or Damaged) – Replacement Cost \$5.00

## **CLASSIFICATION OF STUDENTS**

Students will be classified according to the number of units completed at the beginning of the school year.

Freshmen - 8<sup>th</sup> Grade certificate

Sophomores – 5 credits

Juniors – 10 credits

Seniors – 15 credits

## **REQUIREMENTS FOR GRADUATION**

The State Board of Education and the Board of Regents set minimum graduation requirements and entrance requirements into state colleges and universities. They are as follows:

### **CLASSES OF 2008 AND 2009 requirements**

<b>Courses</b>	<b>Requirements</b>
English/Language Arts	1½ units of writing, 1 ½ units of literature (including ½ credit of American Literature), ½ unit of speech, and ½ unit of other language arts <b>Total of 4 units</b>
Social Science	1 unit of US History, ½ unit of US Government, ½ unit of Geography, and 1 unit of other social science <b>Total of 3 units</b>
Math	1 Unit of Algebra or higher. Parkston requires 1 unit of Geometry. <b>Total of 3 units.</b>
Science	2 units of a lab science. Parkston requires Physical Science and Biology I. <b>Total of 2 units.</b>
Computer Studies	½ unit of laboratory computer studies. <b>Total of ½ unit.</b>
Fine Arts	1 unit of fine arts. <b>Total of 1unit.</b>
Electives	<b>Total of 8 ½ units</b>
<b><u>Total need for graduation</u></b>	<b><u>22 units or credits</u></b>

**CLASSES OF 2010 AND UP**

<b>Courses</b>	<b>Requirements</b>	
	<b>Standard</b>	<b>Advanced</b>
English/Language Arts	Same as 2008 and 2009 <b>Total of 4 units</b>	Same as 2008 and 2009 <b>Total of 4 units</b>
Social Studies	1 unit of US History ½ unit US Government ½ unit of Geography ½ unit of World History ½ unit of other social science <b>Total of 3 units</b>	1 unit of US History ½ unit of US Government ½ unit of Geography ½ unit of World History ½ unit of other social science <b>Total of 3 units</b>
Math	3 units of Math of which 1 unit or Algebra I or higher Parkston requires Geometry <b>Total of 3 units</b>	3 units of Math of which one unit each on Algebra I, Algebra II and Geometry <b>Total of 3 units</b>
Science	2 units of a lab science Parkston requires Physical Science and Biology I  <b>Total of 2 units</b>	3 units of lab science that must include a minimum of biology and chemistry or Physics. Parkston requires Physical Science and Biology I <b>Total of 3 units</b>
Fine Arts	1 unit of Fine Arts <b>Total of 1 unit</b>	1 unit of fine arts <b>Total of 1 unit</b>
Computer Studies	Parkston requires ½ unit <b>Total of ½ unit</b>	Parkston requires ½ unit <b>Total of ½ unit</b>
PE/Health	½ unit of PE or Health <b>Total of ½ unit</b>	½ unit of PE or Health <b>Total of ½ unit</b>
Economics/Personal Finance	½ unit of Economics/ Personal Finance <b>Total of ½ credit</b>	½ unit of Economics/ Personal Finance <b>Total of ½ credit</b>
Other	2 units of any combination of the following required offerings: World languages or computer studies or approved CTE courses or math courses in additions to requirements above or science courses in addition the requirements above. <b>Total of 2 units</b>	2 units of any combination of the following required offerings: World languages or computer studies or approved CTE courses or math courses in addition to requirements above or science courses in addition to requirements above. <b>Total of 2 units</b>
Electives	6 units	5 units
<b>Total needed for graduation</b>	<b>22 credits</b>	<b>22 credits</b>



If a student fails a course, it must be made up at the earliest possible time. One option is to make up the course by correspondence, at the student's expense. Any correspondence course must be completed by May 1 their senior year if the student wishes to take part in the graduation exercises. Some courses are not available by correspondence and must be completed in the classroom.

**IF A STUDENT ELECTS TO MAKE UP A COURSE BY CORRESPONDENCE THEY WILL NOT BE GRANTED SENIOR PRIVILEGES.**

## **SOUTH DAKOTA OPPORTUNITY SCHOLARSHIP BACKGROUND AND HISTORY OF SCHOLARSHIP**

The South Dakota Legislature authorized the Regents Scholarship Program in 2003 to allow South Dakota's most academically accomplished high school graduates to receive an affordable education at any university, college, or technical school in South Dakota that is accredited by the North Central Association (NCA). In 2004, the Legislature renamed the scholarship the South Dakota Opportunity Scholarship and authorized funding from the state of South Dakota's Education Enhancement Trust Fund, beginning with high school graduating classes in 2004.

### **Scholarship Amounts**

The South Dakota Opportunity Scholarship provided \$5000 over four years to a qualifying student who attends an eligible higher education institution in South Dakota:

- \$1000 – 1<sup>st</sup> year of attendance
- \$1000 – 2<sup>nd</sup> year of attendance
- \$1000 – 3<sup>rd</sup> year of attendance
- \$2000 – 4<sup>th</sup> year of attendance

One-half of the annual scholarship award will be distributed at the beginning of the fall semester and the other half distributed at the beginning of the spring semester. NOTE: If the number of eligible recipients exceeds the amount of money appropriated for the scholarship by the South Dakota Legislature, the scholarship may be prorated and distributed to each recipient proportionately.

### **ELIGIBILITY REQUIREMENTS**

- Be a resident of South Dakota at time of high school graduation
- Have an ACT composite score of 24 or higher. If using a SAT score, the sum of the verbal and mathematics scores on the SAT must be at least 1070.
- Complete high school course requirements commonly known as the Regents Scholar curriculum with no final grade below a C (2.0 on a 4.0 scale) and a cumulative high school GPA of 3.0 on a 4.0 scale (grade of B). The Regents Scholar curriculum is as follows:
  - 4 units of English** (courses with major emphasis upon grammar, composition or literary analysis; one year of debate instruction may be included to meet this requirement).
  - 3 units of social studies** (such as history, economics, sociology, geography, U.S. or South Dakota government, American problems etc.)
  - 4 units of algebra or higher mathematics** (algebra, geometry, trigonometry, or other advanced mathematics, as well as accelerated or honors mathematics [algebra] at the 8<sup>th</sup> grade level, shall be accepted). NOT INCLUDED are arithmetic, business, consumer or general mathematics or other similar courses.
  - 4 units of science, including 3 units of approved laboratory science** (courses in biology, chemistry, or physics in which at least one regular laboratory period is scheduled each week). Accelerated or honors science (biology, physics, or chemistry) provided in the 8<sup>th</sup> grade shall be accepted. Qualifying physical science or earth science courses (with lab) shall be decided on a case-by-case basis.
  - ½ unit of computer science** (students will have basic keyboarding skills and have had experience in using computer word processing, database, and spreadsheet packages and in using the Internet or other wide area networks).
  - 1 unit of fine arts** (in art, theatre, or music – appreciation, analysis, or performance).
  - 2 units of the same modern or classical language** (includes American Sign Language).

*Note: 1 unit of high school credit equals 1 year of instruction.*
- Attend a university, college, or technical school accredited by the North Central Association (NCA) and that provides instruction from a campus located in South Dakota.
- Enter into program within 5 years of high school graduation, or within 1 year of the student's release from active duty military service (if that release is within 5 years of the date of the student's high

school graduation). **Eligibility is lost if the student attends full time (12 or more credit hours per term on a semester basis) an institution of higher education located outside South Dakota.**

- May participate in South Dakota Opportunity Scholarship Program for the equivalent of four academic years (eight consecutive fall and spring terms), or until attaining a baccalaureate, associate, or technical degree, whichever comes first.

### **CONTINUING ELIGIBILITY REQUIREMENTS FOR SCHOLARSHIP RECIPIENTS**

- Maintain a cumulative 3.0 grade point average on a 4.0 scale, calculated after the second semester and every semester thereafter.
- Complete consecutive spring and fall academic terms in order to remain eligible for continuation of scholarship from term to term. The scholarship does not apply to summer terms.
- Complete a minimum of 15 credit hours of instruction per term (Remedial courses do NOT count toward the 15-hour requirement).
- Sit for and meet, on the first attempt, the minimum passing scores established by the Board of Regents on all sections of the BOR college proficiency examination. The proficiency examination is required in the Fall or Spring term after which the baccalaureate degree-seeking student has completed 48 credit hours.

### **APPLICATION PROCEDURE**

- Complete the South Dakota Opportunity Scholarship Application Form.
- Attach official high school transcript
- If the student's official high school transcript does not show the ACT composite score or the sum of the SAT verbal and mathematics score, attach a copy of the student's ACT or SAT Score Report.
- Turn in the application form to the university, college, or technical school admissions office. **It is recommended that the initial scholarship application be submitted by June 1, so that the financial aid office can begin to work with eligible students to package a scholarship award.**
- **The final due date for submission of the application form in August 15<sup>th</sup>.**

#### **For more information contact:**

South Dakota Board of Regents  
South Dakota Opportunity Scholarship Program  
306 E. Capitol Ave., Suite 200  
Pierre, SD 57501-2545  
(605) 773-3455  
E-Mail: [info@sdbor.edu](mailto:info@sdbor.edu)      Web site: [www.sdbor.edu](http://www.sdbor.edu)

### **TO PICK UP THE SOUTH DAKOTA OPPORTUNITY SCHOLARSHIP APPLICATION FORM – STOP BY THE HIGH SCHOOL OFFICE OR GUIDANCE OFFICE.**

## **GRADES AND HONOR ROLL**

Every nine weeks, grades will be issued to each student in each course pursued. The faculty realizes the difficulty in determining accurate grades. However, in general, grades are an indication of the quality of work the student is doing. Grades, when compared with student's ability, reveal the extent of such character traits and ambition, industry, perseverance and attitudes. Excellent grades do not guarantee success as well as low grades do not necessarily mean failure. Grades become a recommendation for or against him/her when the record is examined. Considerable importance is attached to grades attained by students by agencies seeking recommendations. Therefore, every student should attempt to obtain the highest grades that he/she is capable of attaining. Report cards will be issued at the conclusion of each nine weeks period. The grade on the card will represent an average of all work done. Comprehensive semester examinations will be given in each subject. The dates of these examinations will be announced prior to end of the each semester. **NO STUDENT WILL BE EXCUSED FROM SEMESTER EXAMINATIONS FOR ANY REASON.** All subjects will be graded on the basis of A+, A, A-, B+, B, B-, C+, C, C-, D+, D, D- or F. An incomplete will be given only when there has been a prolonged illness or injury near the end of a nine weeks. All incompletes must be removed within three weeks or they become F's.

## HONOR ROLL

7<sup>th</sup> and 8<sup>th</sup> Grade

Roll of Excellence – 4.0  
Honor Roll – 3.5 to 3.99  
Merit Roll – 3.0 to 3.49

9<sup>th</sup> through 12<sup>th</sup> Grade

Roll of Excellence – 4.0  
Honor Roll – 3.5 to 3.99  
Merit Roll – 3.0 to 3.49

## CARE OF TEXTBOOKS

Students receive textbooks for each subject carried. Texts are issued for the student by the teachers at the first meeting of the class. Each text is numbered and graded to the quality. This information is recorded by each teacher. If textbooks are lost, injured or show more than normal wear, teachers are asked to exact fines for the same. The teacher is the judge in this matter. If there are any questions, he/she may consult the principal. USE but don't abuse your books.

## GUIDE FOR ASSESSING BOOK FINES

If book is lost:

New this year – Full value  
New last year – 4/5 value  
New two years ago – 3/5 value  
New three years ago – 2/5 value  
New four years ago and thereafter – 1/5 value

Other:

Backs or covers broken – 1/2 value of book  
Pages torn and un-mended – 5 cents per page  
Ink writing, spots, etc. – 2 cents per page  
Pencil marks not erased – 5 cents to 50 cents for book  
Miscellaneous – use own judgment

## CO-CURRICULAR ELIGIBILITY POLICY AS SET BY PARKSTON HIGH SCHOOL

**PURPOSE:** The purpose of this policy is to set forth the Board of Education position related to student eligibility for participation in co-curricular activities.

**PHILOSOPHY:** The Parkston Board of Education believes that co-curricular activities have a significant potential to contribute positively to student development. The Board believes that it is reasonable to require high minimum standards of academic achievement for students who wish to participate in co-curricular activities, since it holds that academic study must be the primary focus of the school. Further, the Board recognizes its responsibility to assist students in a positive manner on the questions of activity eligibility and academic achievement. This policy statement clearly exceeds the SDHSAA requirements for participation in co-curricular activities. The policy below sets forth the expectations, requirements, and procedures related to co-curricular participation eligibility.

At the end of the first two weeks of the first nine week period, all teachers will submit to the principal's office a list of students who have earned a D- or an F for that period of time. **Grades will be collected and the eligibility list will go into effect at 8:30 Monday morning and will remain in effect until the next Monday morning at 8:30.** Students receiving less than a cumulative 1.0 GPA (on a 4.0 scale) in all graded subjects (minimum of five) or an F in any subject at that point will be placed on academic probation. This does not affect their eligibility. The principal will inform the student's parents and the student's teacher. The student will remain on probation until mid-term, when their grade will determine their eligibility. If the cumulative grade is 1.0 or above with no failing grade, the student is eligible; in not, the student becomes

ineligible and the principal informs the parents. The student will have one full week to meet with the teacher and raise the grade above an F or cumulative grade to 1.0 with no failing grade. If the student meets the above criteria, the student is eligible. If not, there will be a weekly review until the grade is improved to at least a cumulative 1.0 average with no failing grade. The student may continue to practice, but cannot participate in contests.

Students who have maintained a cumulative 1.0 GPA with no failing grade will have the process repeated at the beginning of each nine-week period. Students who are ineligible at the end of a nine-week period will be ineligible until the two week grades are submitted in the succeeding nine-week period, meeting minimum guidelines.

Students that are failing at the end of the 1<sup>st</sup> and 3<sup>rd</sup> nine weeks will be ineligible for the next two weeks. At the end of the 2<sup>nd</sup> and 4<sup>th</sup> nine weeks the semester grade will determine eligibility. If a student fails for the semester he/she will be ineligible for the next two weeks.

Students who are ineligible at the end of a semester are not eligible in the succeeding nine-week period until the two week grades are submitted in the succeeding nine-week period, meeting minimum guidelines. The principal is charged with the responsibility of compiling the following information: the name, subject(s) and teacher(s) of the students who are ineligible or on probation. The principal will convey that information to the teacher of the student. The principal is responsible for developing procedures for carrying out this policy. No eligibility list will be posted anywhere; a list shall be forwarded to each teacher and to the superintendent's office. To participate or attend a school sponsored activity a student must attend school for at least two blocks that day, unless they have prior approval from the principal.

Because the SDHSAA has their eligibility policy and Parkston High School has their own eligibility policy, we must follow both policies. Parkston's is listed above and the SDHSAA is listed below.

### **JUNIOR HIGH ELIGIBILITY**

Upon collection of grades each Monday, any junior high student failing 2 or more courses shall be ineligible for any extra curricular activity until the following Monday's review of grades. This policy will be in effect 2 weeks into each semester. This policy is only in effect for all junior high events. Any junior high student that participates at the high school level must meet the standards of the high school eligibility policy.

## **ELIGIBILITY POLICIES AS SET BY THE STATE OF SOUTH DAKOTA**

### **GUARD YOUR ATHLETIC ELIGIBILITY YOU ARE NOT ELIGIBLE IF:**

- You have reached your 20<sup>th</sup> birthday
- You have attended more than 4 first semesters and 4 second semesters of school in grades 9 through 12. Enrollment in school for 15 school days or participation in an inter-school contest shall constitute a semester. Once a student enrolls as a ninth grader, all semesters must be consecutive unless verified in writing by a physician that withdrawal from school is necessary due to a serious illness or injury.
- You did not pass 20 hours of high school work per week, in courses approved for graduation for the preceding semester.
- You are not enrolled in and attend a minimum of 20 hours of high school work per week during the current semester.
- You have graduated from a regular four-year high school or institution of equivalent rank.
- You have not enrolled by the 16<sup>th</sup> school day of the current semester. Date of regular entry into classes is considered the date of enrollment.
- You have been absent from school more than 10 consecutive school days. (Illness of the student or death in the immediate family excepted)

- You have transferred from one high school to another without a corresponding change in the residence of your parents. (Exception made for students who transfer pursuant to the open-enrollment by-law)
- You do not have on file in the principal's office a signed physical examination and parent's permit form.
- You have participated in an athletic contest under an assumed name.
- You have participated in athletics in any institution of learning of higher rank than a standard secondary school.
- You have violated your amateur standing.
- During a high school sport season, you compete on an unattached bases as an individual or as a member of a non-school team.

**CONSULT YOUR COACH OR PRINCIPAL FOR ADDITIONAL INFORMATION**

**GUARD YOUR FINE ARTS ELIGIBILITY  
YOU ARE NOT ELIGIBLE IF:**

The following are the eligibility requirements for students participating in any contest or festival involving music, journalism or speech and drama activities.

- You have reached your 20<sup>th</sup> birthday
- You have attended more than 4 first semesters and 4 second semesters of school in grades 9 through 12. Enrollment in school for 15 school days or participation in an inter-school contest shall constitute a semester.
- You did not pass 20 hours of high school work per week, in courses approved for graduation for the preceding semester.
- You are not enrolled in and attend a minimum of 20 hours of high school work per week during the current semester.
- You have graduated from a regular four-year high school or institution of equivalent rank
- You have not enrolled by the 16<sup>th</sup> school day of the current semester. Date of regular entry into classes is considered the date of enrollment.
- You have been absent from school more than 10 consecutive school days. (Illness of the student or death in the immediate family excepted)

**CONSULT YOUR PRINCIPAL OR FINE ARTS COACH/DIRECTOR FOR ADDITIONAL INFORMATION**

**SOUTH DAKOTA HIGH SCHOOL ACTIVITIES ASSOCIATION**

**STUDENT CONDUCT AT ATHLETIC ACTIVITIES AS SET BY THE STATE  
ACTIVITIES ASSOCIATION**

**NO BANNERS – NO NOISEMAKERS**

- Temporary banners and signs of all kinds are prohibited except those displayed by the SDHSAA, cheerleaders, the tournament band, the arena, the tournament manager and licensed radio and television stations.
- All types of noise makers, as well as all sorts of projectiles are prohibited
- Paper confetti, because it is difficult to clean up as well as a fire hazard, is prohibited.
- There will be **NO** balloons permitted in the armory.
- Megaphones, except when used by a cheerleader, are prohibited
- Musical instruments, except when the band is performing, are prohibited.
- Stereo tape decks and related radio equipment are prohibited, except when used for between game and halftime entertainment.

**STUDENTS STANDING DURING BALL GAMES:**

It is the policy of the SDHSAA that all aspects of the State Basketball tournaments be conducted in a manner whereby consideration is given to all fans, students and adults alike. In recent years there has been a trend for students to stand during the game and thus block the view of the fans in the first rows of the reserved seat section. The Board of Directors respectfully requests that all students remain seated while the game is in progress as a matter of common courtesy to the fans in the reserved seat section.

**CHEERLEADER RULES:**

- In some instances cheerleaders remain too close to the playing floor during play. Cheerleaders, for the protection of all, shall take a position that will not interfere with the game being played.
- Only varsity basketball cheerleaders will be permitted on the playing floor at the state tournaments. This means that “B” team cheerleaders and adult fans will not be allowed to assist in leading cheers at any state tournament game.
- Spirit or yell leaders will be allowed provided they are so designated by their school and appear in a school approved uniform.
- Homer hankies, towels, pom poms, small triangular pennants, foam rubber hand - #1 and signs that cheerleaders hold are acceptable and permissible.
- Hoops, mint-tramps and tunnels.
  - 1) The use of “break-through” hoops are prohibited.
  - 2) The use of mini-tramps, rebounding devices and related pieces of equipment are prohibited.
  - 3) Human tunnels created by student and/or adult fans are prohibited.

**LIST OF ACTIVITIES**

List of the activities offered at Parkston Junior/Senior High school. They are listed according to curricular and co-curricular. Curricular are not affected by the eligibility policy, but co-curricular activities are affected by the eligibility policy.

Activity	Curricular	Co-curricular
Basketball		X
Football		X
Volleyball		X
Track/Cross Country		X
Golf		X
Wrestling		X
Cheerleading		X
Drama (Plays)		X
Band – Concerts	X	
Contests		X
Vocal – Concerts	X	
Contests		X
Journalism – Paper	X	X
FCCLA		X
FBLA		X

**Any student that is ineligible will not be able to attend an out of school function that occurs during the school day.**

**STUDENT ACTIVITIES**

The activity programs in the Parkston Public Schools is planned as an integral part of the student’s education. The School Board requires that each activity be well organized and properly supervised at all times. The district is not responsible for students who utilize school facilities under the following conditions:

1. Unauthorized
2. Unscheduled
3. Unsupervised

4. When the facilities have been rented to some outside agency.

### **PLAYING UP POLICY**

The Parkston School District will follow the state policy regarding seventh and eighth grade athletes playing up with the decision being left up to the athletic director, the head coach of said sport and the parent of that child, with that child falling under the Parkston Public School's academic eligibility policy.

High school students must have the first opportunity to become student managers, statisticians, and video-tapers. If no high school students want to fill these positions, then the coach of the activity may ask seventh and eighth grade students. Under no circumstances will students below the seventh grade be allowed to participate. Any exception to this rule must be cleared through the administration.

### **ACTIVITY TICKETS**

The purpose of the activity ticket is to give students a reduced admission rate to the various activities during the school year. Each student will be offered an activity ticket which will admit the student to all of the home athletic contests and other school sponsored event as set forth by the administration and school board. The cost of the activity ticket is set by the school board each year. **The activity tickets do not work for the Boy's and Girl's basketball Classics and all District, Region, and State Events. This includes Football Playoff games.**

## **ATTENDANCE**

A Student's success in school requires regular attendance. Parents are urged to assist the school by encouraging good attendance. There are various circumstances that may prevent a student's attendance for a day or a number of days. In such cases, the student will be given the opportunity to make up the work and receive full credit. Make-up time of one day for each day missed will be allowed.

When a student has been absent from school, whether it be a part of the day or longer, **HE/SHE MUST PRESENT AN EXCUSE WRITTEN BY A PARENT OR GUARDIAN STATING THE REASON FOR THE ABSENCE.** An admit slip to class will then be issued by the principal's office. Students will then present their admit slip to the teachers of their classes and they will be given the make-up work assignments for each class missed. When the work is made up, the admit slip will be initialed by the teacher of the class involved. The admit and make-up slip is then returned by the student to the office. **NO STUDENT WILL BE ADMITTED OFFICIALLY TO CLASS WITHOUT AN ADMIT SLIP.**

**These slips are to be turned into the office the day they are dated. Failure to do so will result in no credit. If a student makes a habit of being lat with these slips he/she will make up time after school which will be determined by the administration.**

At no time will a student leave the school building without permission from the principal's office. If a student is granted permission from the principal's office, this permission will be in the form of a written permit issued by the office. If a student violates this rule they will be subject to a possible three day suspension with zeros.

**ANY STUDENT THAT HAS MISSED MORE THAN 10 DAYS IN A SEMESTER WILL BE ASSIGNED A SATURDAY SCHOOL DETENTION. (BEING ABSENT FROM SCHOOL FOR A SCHOOL ACTIVITY DOES NOT COUNT TOWARDS THE 10 DAYS).**

A student who has been or will be absent representing the school in an official capacity need not bring an excuse covering the time absent. This will be taken care of by the person in charge of the activity.

### **TYPES OF ABSENCES:**

Each block missed will count as ¼ of a day. All absences are either excused, exempt (school activities) or unexcused. A letter will be sent out when a student misses 6 days. Another letter would go out when a

student misses 8 days and when a student misses a total of ten day a letter will go out stating that if the student missed another day of school, that it will be turned over to the truancy officer.

Miscellaneous Provisions:

1. Release from School  
**No student is to leave the school premises without the principal's permission. If a student is ill or has to leave, he/she will check with the principal's office and get permission to leave early if necessary, otherwise the student is to be where assigned.**
2. Supervision  
If suspended, no student will be allowed to participate in any school activity for the term of the suspension. The student will not be allowed to attend any school function during the suspension.
3. Students being sent home  
Students should have a place to go in case there is no one home. Parents and/or guardian should be notified prior to the dismissal of kindergarten children in inclement weather or when a child is sick. No elementary child is to be sent home without parental notification if the child is sick.
4. Emergency shelter  
The Parkston School District #33-3 feels we need a plan to house student in the event we are unable to send students home on the bus. This might be caused by a sudden wind and/or snow creating blocked roads before the buses could be sent out. We would like to have this record on file telling us where you wish to have us sent your child should an occasion like this arise.

With the aforementioned in mind, the following attendance policies have been adapted by the Board of Education of the District #33-3.

1. **Excused Absences:** are those absences which are sanctioned by the school and the parent and school work will be allowed to be made up for credit. An excused absence will be granted upon receipt of a written, signed explanation from the parent or guardian and/or a phone call from the parent or guardian. Any student making no attempt to make up work prior to an absence that they know of at least one day in advance may receive zero's for the work.

The following are legitimate reasons for which an excused absence may be granted:

- Participation in school sponsored activities.
  - Absences due to prolonged illness or a series of medical or dental treatments. (Doctor's statement may be required by school administrator)
  - Absence due to bereavement or serious illness in the student's immediate family.
  - Legitimate work absence – Parkston Public Schools does not issue work permits as such. Up to seven absences per semester from an academic class may be missed for work purposes. At this point in time a conference will be held with the student, parent and administration. Refer to unexcused absence.
  - Vacation trips accompanied by parents – make up work – one day for every day missed.
  - No student shall leave the school premises without permission from the office. A violation of this paragraph shall be treated as skipping school and discipline will follow the discipline grid (Page 25). It will also result in being called an unexcused absence with zeros.
  - If and when an excused absence should be violated by a student, the excused absence will immediately become unexcused and will be dealt with as such by the rules pertaining to an unexcused absence.
2. **Unexcused Absences** - The district realizes parents have the right to take their children out of school. However, absence (other than the above mentioned excused absences) which is sanctioned only by the parents will be classified as unexcused; and the student will not be allowed to make up the work for credit.
    - After a student has been absent seven (7) times from any class during a semester, a conference will be held with at least the principal, the student and one parent in attendance. The purpose of the conference shall be to inform the parent and the student that because he/she has accumulated excessive absenteeism, the student will be dropped from the class on the next absence.
    - Tardiness – Promptness in getting to class is very important and is strongly encouraged by the public school.



### **ONLY PRINCIPAL MAY RELEASE;**

Teachers are not to release pupils from school without the prior approval of the Principal. No pupil will be released from school to go with any adult other than the mother or father of the child without the principal first obtaining the following information:

- The name of the person with whom the child is going  
Verification, parental or guardian permission of  
The authority and of the person to take this child  
(Phone call is encouraged)
- That a valid reason exists for the child to be released
- If a student is to leave school early for any activity or be absent for a day for any activity, work must be taken care of prior to their leaving.

### **SCHOOL DAY**

The school day consists of four class periods, beginning at 8:15 a.m. and ending at 3:15 p.m., with five minutes between classes. We have the block schedule at Parkston Junior/Senior High School with the days alternating and they are called Blue and Orange Day.

#### **Blue/Orange Day**

##### **First Lunch**

8:15 – 9:45 Period 1

9:50 – 11:20 Period 2

11:20 – 11:50 Lunch

11:55 – 1:25 Period 3

1:25 – 1:40 Reading Period

1:45 – 3:15 Period 4

##### **Second Lunch**

8:15 – 9:45 Period 1

9:50 – 11:20 Period 2

11:25 – 12:30 Period 3

12:30 – 12:55 Lunch

1:00 – 1:25 Period 3

1:25 – 1:40 Reading Period

1:45 – 3:15 Period 4

### **STUDY HALLS**

Study halls are periods for work – not for rest and relaxation. All students will be assigned to study hall when not in class.

1. Every student must bring work or reading material to study hall.
2. Any group causing a disturbance will be informed by the supervisor that “no talking” will be in effect for that group the remainder of the period.
3. We realize that detention can cause problems for parents, students and teachers. However, disturbances and failure to observe regulations cause problems on a much larger scope. Therefore, when necessary study hall supervision will assign detention for violations. This detention will be made up within twenty-four hours as determined by the supervisor and supervisor phoning the parents and arranging the detention. Detention is a punitive measure used to deter unaccepted behavior. If, after three detentions unaccepted behavior continues, the student will be suspended on a short term basis and a conference arranged with the parents.
4. The last five minutes of each study hall will be used to clean up the room.
5. No pop or food in the media center or any other class room
6. Passes permitting students in the hallway will not be issued during the first fifteen minutes of any period. However, a pass issued from a classroom teacher permitting a student to come to his/her room for help will be honored at any time by the study hall supervisor. Students may go to the guidance office after notifying the study hall supervisor.
7. The library is a place for quiet study. Anyone not abiding by the rule will be sent out.

### **MEDIA CENTER**

The library is provided for all school students; however, it is a privilege, not a right and may be revoked at any time.

1. Books and magazines can normally be checked out for two weeks at a time.

2. Reference books may not be removed from the library except by permission of the librarian.
3. Students who lose or damage books or magazines will pay for them.
4. There will be no talking unless by permission of the librarian.
5. Candy and gum will not be allowed in the library or other classrooms.
6. Assistant librarians are authorized to check books in and out and to enforce the rules of the library.
7. Books and magazines on reserve may be checked out for one period or overnight as permitted by the librarian.
8. Current magazines will be read in the library only.

### **FINES**

No fines will be charged on overdue books until they are listed in the announcements as overdue. A ten cent per day fine (50 cents per week) will then start accumulating. When the fine reached is \$1.00, the student will be billed for the cost of replacing the item.

### **LOST BOOKS**

To prevent fines from accumulating, report a lost book immediately. It will be placed in the lost file and if it is not found within a two month period, the book must then be paid for. The cost of replacing the book will be charged.

### **HALLWAY RULES**

All students are to observe the following rules in regard to the hallways.

1. No loitering or congregating in large groups in the halls at any time
2. Boisterous conduct, yelling and unnecessary disturbances cannot be permitted
3. Walk, do not run through the halls.
4. Keep the halls clean and neat at all time.
5. At all times observe rules of courteous and consideration for others.
6. Students in the halls during class time must have passes.

### **CHEATING**

Whenever a student is guilty of cheating, the teacher shall collect the student's paper, mark a zero for the work, and notify the parent and office immediately as to the action taken. For discipline refer to the discipline grid on Page 25.

### **TELEPHONE**

Students will not use the office phone for personal calls except in emergencies and with staff permission. In the event a student receives a call he/she will be called out of the class only in the case of an emergency. Normally phone calls for student will be handled after school. The phone in the lobby of the armory is for student use.

### **SCHOOL DANCES AND PARTIES**

School dances and parties regardless of where they are held are under the school's jurisdiction.

### **CAFETERIA – LUNCH PERIOD**

Student behavior in the lunchroom is expected to be the same as the class room.

1. Students are to remain in the lunch room/lobby for the entire lunch period.
2. No student will be allowed to go down the hallway during lunch (other classes are in session)
3. No pop in the lunchroom during lunch.
4. No driving at noon, except in an emergency or hardship and this is granted by the principal only.
5. Students should bring their lunch money to the office in the morning.

### **FIRE DRILLS AND TORNADO DRILLS**

1. Fire drills are held at various times during the school year. When the bell sounds, all students and staff members will leave the building quickly and quietly (walk fast, do not run, do not talk). Directions are posted in each room for all person to follow. All students are requested to read the directions for fire drills so you will familiar with which route to take to speed up evacuation of the building.
2. Tornado drills will be held in the spring to show the students where to go in the case of a tornado. All students will get into the main hallway and in the proper position.

### **LOCKERS**

The school provides lockers for the students and one locker is assigned to each student at Parkston Jr./Sr. High School. The students are expected to keep their books, coats and anything else need while in school in their locker. Students are expected to keep their lockers clean at all times. The school assumes no responsibility for articles lost or stolen from the lockers. The security and condition of the lockers are the responsibility of the students. Lockers may be checked by the principal at any time. If at any time during these checks or searches, school officials find anything stolen or unsafe to students or others, school officials may seize these items from the locker and turn such items over to the proper authorities.

### **INSURANCE**

The Parkston schools will offer student insurance to all students at a nominal fee. There are two types of coverage under the program.

1. Ordinary coverage (2 options – with various deductibles and school time and 24 hour coverage).
2. Football coverage additional to base plan.

**ALL ACCIDENTS MUST BE REPORTED IMMEDIATELY TO THE ADMINISTRATION OF THE SCHOOL.**

### **CHURCH NIGHT**

Wednesday night has been designated as church night. The school will do its best not to schedule any activity on this night. There may be exceptions to this, but it is out of our hands when this happens. By setting Wednesday as church night it allows the students to participate in the youth activities of the respective churches.

### **NO SCHOOL ANNOUNCEMENTS**

If the decision to discontinue classes for the day is made, an announcement to that effect will be made on radio WNAX, KMIT, KQ107 and KORN, usually about 7:00 am. If weather conditions clearly warrant not having school the next day due to a heavy storm late in the afternoon or early evening, announcements to that effect will be made on KSFY, KELO, and KDLT television.

**IF SCHOOL IS CALLED OFF OR DISCONTINUED, ALL ACTIVITIES ARE SUSPENDED UNLESS THE SUPERINTENDENT AND/OR PRINCIPAL DEEM OTHERWISE.**

### **PRINTED MATERIAL**

1. Material such as magazines and posters will not be distributed in school by non-district employees without permission of the principal.
2. Parkston Schools will not tolerate obscene materials or any materials that advocate violence.
3. All district owned material must conform to the policies laid down by the Board of Education as described in the policy book.

### **STUDENT APPEARANCE AND CONDUCT**

Student will be expected to keep themselves well-groomed and neatly dressed at all times. Any forms of dress which is considered contrary to good hygienic or which is distractive or disruptive in appearance and detrimental to the purpose of the conduct on the school will not be permitted. Shorts will not be permitted by

boys or girls (except during extremely warm weather and at the discretion of the principal). Tube tops, halters, muscle shirts or similar items of clothing will not be worn to school. Clothes advertising alcoholic beverages or those with obscene or questionable printing on them will not be permitted. **Any shirt worn in school must have appropriate writing. Any message that can be taken in a way that is of a sexual nature will not be able to be worn in school.**

**Students may not print up any article of clothing or print something on any object that is in reference to an activity sponsored by the Parkston School District unless the print on the article of clothing or object has gained the approval of the athletic director or administration of the Parkston School District. The Parkston School District has a trademark for the use of the Parkston Trojans for any school activity.**

Students are expected to display proper behavior towards other students, faculty, administration and all other adult persons affiliated with the school. In regard to other students, and conduct that appears seductive in nature will be considered as disruptive behavior and could result in suspension.

A student's conduct is a personal matter that he/she should keep within reasonable bounds that apply equally to all members of the community. He/she should have freedom and encouragement to express his/her individuality in school in any way so long as his/her conduct does not intrude upon and endanger the freedom of others – especially upon the freedom of his/her peers to receive instruction. The Board's intent is to establish a rational position between freedom for each individual and the necessity for sufficient order to permit the operation of the instructional program.

All students, on the other hand, should recognize the consequences of their conduct. This refers to their actions toward each other, to their language, to their dress and to their manners.

Students both individually and in groups shall comply with school regulations, and shall recognize the authority of the teachers. Disobedience or open defiance of the teacher's authority shall constitute sufficient cause for disciplinary action and may result in suspension or expulsion from school. When, in the judgment of a teacher, an individual or a group effectively challenges his/her authority to conduct meaningful instruction in a classroom through disruptive acts, abusive language, or threat of bodily harm, the teacher shall report such activity at once to the principal who is empowered to institute appropriate corrective and/or disciplinary action.

It shall be the policy of the District #33-3 School Board that the student handbook herein containing the rules and regulations will be the directives under which the school system of this district be administered.

Each and every student will be advised thereof and will thereafter be expected to know the policy explaining the rules and regulations of this school system. Ignorance of the policy will not be accepted as a valid excuse for non-compliance.

The school principals may supplement the regulations herein listed when this becomes necessary to maintain order under unusual circumstances in their respective schools.

### **ACTIVITIES – RESPONSIBILITIES AND REGULATIONS FOR STUDENTS**

All students are considered to be under the jurisdiction of the regulations in the policy on Student Behavior while going to, remaining at, and returning from school, and at any time they visit another school that is in session.

The Board of Education advocates that while education is a right of our youth, it is not an absolute right. It is qualified first by eligibility requirements and second by performance requirements. The school must be concerned with the individual and his/her welfare, but in working with the individual, must at all times be concerned with the welfare of the group.

The following obligations should be assumed by the student:

1. To obey the rules of the school.
2. To apply himself/herself to the established course of study.
  - Be prompt and regular in attendance

- Complete school assignments on time
  - Pay attention to teachers
  - Be willing to work at self-improvement
  - Learn to criticize fairly and accept criticism
3. To respect the authority of his/her teachers
  4. To respect school property
  5. To conduct himself/herself properly in school, on school grounds, buses and at school functions.
  6. To refrain from disruption, demonstrations, violence and other forms of incitement.
  7. To leave the school grounds immediately upon being dismissed unless engaged in some school sponsored activity directed by a faculty member.

The Board and Administration cannot develop a policy in such detail as to anticipate every type of misconduct that could occur. Generally those rules of conduct which are considered acceptable in the home, church and in other such places will be acceptable in school.

### **CODE PROHIBITING SERIOUS MISCONDUCT**

#### **Rule 1 – Disruption of school**

A student shall not, by use of violence, force, noise, coercion, threat, intimidation, fear, passive resistance, or any other conduct cause the substantial and material disruption or obstruction of any lawful mission, process or function of the school.

A student shall not participate in a boycott, sit-in, stand-in or walk-out that is disruptive to the conducting of school, or that is a non-peaceable gathering.

A student shall not urge other students to engage in conduct that will disrupt the school if it is reasonably certain that this conduct will disrupt the school's purpose.

#### **Rule 2 – Damage or Destruction of School Property**

A student shall not intentionally cause or attempt to cause damage to valuable school property, or steal or attempt to steal school property.

#### **Rule 3 – Damage or Destruction of Private Property**

A student shall not intentionally cause or attempt to cause damage to valuable private property, or steal, or attempt to steal valuable private property either on school grounds, or during a school activity, function or event off school grounds.

#### **Rule 4 – Abuse of School Personnel**

Neither student, parent of a student, or person acting for a student, may use any form of violence or abusive language to a teacher or school administrator or other school personnel, or cause damage to be inflicted on the property of such persons.

#### **Rule 5 – Physical Abuse of a Student or Other Person Not Employed by the School**

A student shall not intentionally do bodily injury to any person (1) on the school grounds during and immediately before or immediately after school hours. (2) on the school grounds at any other time when the school is being used by a school group or (3) off the school grounds at a school activity or event.

#### **Rule 6 – Weapons and Dangerous Instruments**

A student shall not knowingly possess, handle or transmit on school premises or off the school grounds at any activity or event, knives, guns, or other weapons, dangerous objects, fireworks, or any other object that can reasonably be considered a weapon.

### **SOUTH DAKOTA CODIFIED LAWS AND CONSTITUTION**

- **13-32-7. Possession of firearms on elementary or secondary school premises or vehicles as misdemeanor – Exceptions. Any person, other than a law enforcement officer, who intentionally carries, has in his possession, stores, keeps, leaves, places, or puts into the possession of another person, any firearm, or air gun, whether or not the firearm or air gun is designed, adapted, used or intended primarily for imitative or noisemaking purposes, or any**

dangerous weapon, on or in any elementary or secondary school premises, vehicle, or building or any premises, vehicle, or building used or leased for elementary or secondary school junctions, whether or not any person is endangered by such actions, is guilty of a Class 1 misdemeanor. This section does not apply to starting guns while in use at athletic events, firearms, or air guns at firing ranges, gun show, and supervised schools or sessions for training in the use of firearms. This section does not apply to the ceremonial presence of unloaded weapons at color guard ceremonies.

- **26-7A-12.1 Child in possession of firearms on school property may be taken into temporary custody. A child alleged to have violated 13-32-7 may be taken into temporary custody by law enforcement officer who shall immediately notify an intake officer who shall conduct a hearing pursuant to 26-7A-13.**

#### **Rule 7 – Narcotics, Stimulant Drugs and Alcoholic Beverages**

A student shall not knowingly possess, use, transmit or be under the influence of any narcotic drugs, marijuana or intoxicant of any kind (1) on the school grounds at any time, or (2) off the school grounds at school activities, functions or event.

#### **Rule 8 – Use of Tobacco**

The use of tobacco in any form may be hazardous and harmful to the health of students. Therefore, the use of tobacco on school grounds by students is not allowed unless the Board of Education should establish designated areas for students.

- **TOBACCO FREE FACILITY POLICY, PARKSTON SCHOOL DISTRICT**
- Tobacco is an illegal substance for minors. Therefore, any tobacco products, including chew, are not to be in a student's possession while on campus or at school events. The Parkston school is a Tobacco free facility, therefore there will be no use of tobacco on school property. The negative effects of tobacco are well documented. The Parkston School District is committed to encouraging healthful living styles and healthful working environments. Because of this commitment, the following policy will apply to the Parkston School District.
- All K-12 Parkston School District facilities and grounds will be tobacco free in all areas. Tobacco use is prohibited in all K-12 schools and vehicles.
- **Students: Any violation of this policy by students will result in suspension from school for one day. In lieu of suspension, the student may attend an Alternative to Suspension program.**

#### **Rule 9 – Publications**

A student may not produce and/or distribute petitions of any kind, sort or type that is disruptive to the conducting of school. A student shall not produce and/or distribute any petitions or documents of any kind or sort on school premises during the school day without the specific approval of the principal. The Board does endorse regular school publications such as student papers and the yearbook which are produced under the supervision of qualified advisors.

#### **Rule 10 – Student Lockers**

A student shall not place, keep maintain any article or material in a school-owned locker which is on non-school nature that shall cause or tend to cause a disruptive activity on any school property or at any school sponsored function.

#### **Rule 11 – Repeated School Violations**

A student shall not repeatedly fail to comply with directions of teachers, student teachers, substitute teachers, teacher's aides, principals or other authorized school personnel during any period of time when he/she is properly under the authority of school personnel.

### **STUDENT DISCIPLINE – BULLY PREVENTION**

Persistent bullying can severely inhibit a student's ability to learn effectively or a member of the staff's ability to do their job. The negative effects of bullying can have an impact on a person for their entire life. We are committed to providing a caring, friendly and safe environment for all of our students so they can learn in a

relaxed and secure atmosphere. Bullying of any kind is unacceptable. If bullying does occur, all pupils should be able to tell and know that incidents will be dealt with promptly and effectively.

Bullying is repeated and intentional harmful behavior initiated by one or more students and directed toward another student. Bullying exists when a student with more social and or physical power deliberately dominates and harasses another who has less power. Bullying is unjustified and typically repeated. Bullying differs from conflict. Two or more students can have a disagreement or a conflict. Bullying involves a power imbalance element where a bully targets a student who has difficulty defending himself or herself.

The forms of bullying:

- Physical – involves harmful actions against another person’s body
- Verbal – involves speaking to a person or about a person in an unkind or hurtful way
- Emotional – involves behaviors that upset, exclude or embarrass a person
- Sexual – involves singling out a person because of gender and demonstrates unwarranted or unwelcomed sexual advances
- Racial – involves rejection or isolation of a person because of ethnicity

The school board expects students to conduct themselves in a manner in keeping with their levels of development, maturity, and demonstrated capabilities with proper regard for the rights and welfare of other students and staff.

The school board believes that standards for student behavior must be set cooperatively through interaction among the students, parents and guardians, staff and community members of the school district producing an atmosphere that encourages students to grow in self-discipline. The development of this atmosphere requires respect for self and others, as well as for district and community property on the part of the students, staff and community members

The school board requires its school administration to develop and implement procedures that ensure both the appropriate consequences and remedial responses to a student or staff member who commits one or more acts of harassment or bullying

The school board requires the principal and/or the principal’s designee at each school to be responsible for receiving complaints alleging violation of this policy. All school employees, students, parents, visitors or any other member of the community are required to report alleged violations to the school principal. The school principal and/or principal’s designee are to be responsible for determining whether an alleged act constitutes a violation of this policy. In so doing, the principal and or principal’s designee shall conduct a prompt, thorough, and complete investigation of each alleged incident.

The building principals shall develop an annual process for discussing the school district policy on bully prevention with student and staff. The school district will incorporate information regarding this policy in each school handbook.

This policy will go into effect, pending board approval.

## **TRANSPORTATION AND PARKING**

### **TRAFFIC AND PARKING**

Students will park properly and not take up two parking spaces. Students will park in the law just east and north of the lobby doors, of the school. Students **MUST** leave by the north exit during the school day and when the school buses are in the school parking lot. Students are not to park in any driveway or in the fire lanes. Students will not be allowed to do any driving during the school day (including noon) unless they bring in a note and then get permission from the principal.

### **SCHOOL TRANSPORTATION**

1. **Automobiles** – There will be no driving or riding in or on any motor vehicle during the school day without permission from the principal. A student must bring a written statement from his/her parent/guardian, if they wish to drive a vehicle for any reason. This statement must be given to the principal before they leave the school grounds.

2. **Bus Driver Policy** – The students who ride the bus to and from school or to any school event are expected to behave in an acceptable manner. The bus driver will refer any student who causes a disturbance on his/her bus to the principal. Once it is reported the principal will take appropriate action.
3. **Riding of Bus to School Activities** – All students who ride school supported means of transportation to school related functions must return on the same. The parent or guardian of the student may come to the supervisor after the activity has ended, and give the supervisor a note releasing the supervisor of responsibility for the student for the activity. The student will then be turned over to the custody of the parent or guardian ONLY. THERE ARE NO EXCEPTIONS. The students may ride home with school personnel with permission from the parent.

In order to operate a safe, efficient and economical transportation program, it is absolutely necessary that all passengers observe the attached set of regulations. In order to avoid any misunderstandings that might develop at some future date the procedures described below will be followed in case of an infraction of the rules by your child.

When a violation occurs the bus driver will complete the attached form “Notice of violation of rules and regulations while riding the District #33-3 school buses.” This form will be delivered by the driver to the building principal at the student’s attendance center. The building principal will contact the parent(s) about the violation that occurred, visit with the student and/or parent(s) and provide the parent (s) with a statement regarding the violation.

For discipline look at the discipline grid on Page 25.

### **IN TOWN BUS ROUTES**

The Parkston School District is currently providing in town routes to help get the students to the school. The pick-up points have been established, and we request that you determine and tell the school which point is the one you will more than likely be using. These points may be subject to change if the school feels they are not serving the purpose they were intended to serve, or as population shifts in town. In town students will obey the same rules as rural riders. Some students may be denied a ride to school if the buses are already full or past capacity when loading at a point. Bikes should be parked in an orderly fashion when left at a bus point.

### **BUS REGULATIONS**

1. Pupils are under the authority of the bus driver.
2. Pupils shall be on time for the bus both morning and evening.
3. Pupils shall remain seated while the bus is in motion.
4. Pupils shall not extend their hands, arms, or head through the bus windows.
5. Pupils shall converse in normal tones, loud or vulgar language is prohibited.
6. When the bus is crossing a railroad track, all conversation must stop until the bus has crossed the tracks.
7. Pupils who eat on the bus are responsible for putting any garbage in the proper receptacle.
8. Pupils shall keep the bus clean, and refrain from damaging it.
9. Pupils shall be courteous to the driver, to fellow pupils and to passersby.
10. Pupils shall enter and leave the bus at school – loading stations, and at highway bus stops, in an orderly fashion and in accordance with instructions.
11. Pupils must refrain from crowding or pushing.
12. Pupils shall refrain from talking to the driver while the bus is in motion.
13. Each pupil must go directly to his or her seat upon entering the bus.
14. Rough-housing on the bus is prohibited.
15. Pupils must keep feet off the seats.
16. Pupils must keep sharp objects off the upholstery.
17. Pupils must not throw objects about the bus nor out through the windows.
18. Books and other property must be properly stowed out of the way, and the aisle must be clear at all times.
19. Shooting paper wads or other material in the bus is not permissible.
20. Pupils must avoid playing or loitering on the highway when waiting for a bus.

### **WINTER WEATHER TRANSPORTATION**

Decisions to discontinue classes in District #33-3 will be made upon information gathered from rural patrons of the district, radio weather forecasts and/or the weather service in Huron.



If the decision to discontinue classes for the day is made, an announcement to that effect will be made on radio stations, WNAX in Yankton, KDLT, KORN and/or KMIT in Mitchell usually about 7:00 am. If weather conditions clearly warrant not having school the next day due to a heavy storm late in the afternoon or early evening, announcements to that effect will be made on major local TV stations.

In the event that weather conditions warrant sending students home early from school, announcements will be made on radio WNAX and/or KMIT, KORN or major local TV stations and students living in town will be dismissed to go home or to be picked up by their parents.

If weather conditions are severe that buses cannot operate on the bus routes, the Blizzard Buddy System will go into effect. This plan calls for each student not living in town to have indicated to school officials where they would be staying in town if a situation this severe should happen.

It is important that the persons that students are staying with know that the student will be guests if the Blizzard Buddy System needs to be used. Building principals will be responsible for contacting the adults that students would be staying with while the Blizzard Buddy System is in effect.

In the event that there is an extended period of weather conditions that cause only main roads to be opened, buses will travel only where possible and parents will be asked to bring their children to the nearest open road where the bus could pick them up for school. Remember that during the winter months the buses could fail for a variety of reasons while on the route and students could have to wait for a time before assistance arrives, therefore, it is strongly recommended that students dress according to the weather conditions.

Knowing that weather conditions vary throughout the district, parents should always decide as to whether it is safe to send their children to school. School officials will always honor that decision. A call to the building principal or a note will excuse the student for the day of school missed due to weather conditions.

Also, parents of kindergarten children should contact the schools if they are planning to be gone from their home and inclement weather is a threat. The school normally will call the kindergarten parents to alert them of an early dismissal due to the weather.

### **B-J SCHOOL BUSES, INC.**

#### **COLD WEATHER DRESS POLICY**

Realizing the danger involved with cold weather, and the importance of dressing properly for the cold weather, we are establishing the dressing properly for cold weather guidelines as a policy to be followed by schools and bus drivers in the districts served by our company.

1. Coats, gloves and leg coverings should be worn in cold weather when riding the bus on the regular routes and for activity trips.
2. The type of protective clothing needed changes with the severity of the cold temperatures.
3. The bus supervisor shall notify school officials, who then, in turn, shall notify the parents of the violation. The parents shall be urged to dress their children properly.

### **PROHIBITED MATERIALS**

The following materials are prohibited at the Parkston schools. Any student found with such material can be suspended.

1. Alcohol
2. Drugs unless prescribed by a physician
3. Pornographic materials
4. Tobacco
5. Firearms
6. Any other weapon which have the express purpose of causing injury.
7. Electronic Gadgets
8. Walkie-Talkies
9. CD Players
10. Cell Phones – The use of cell phones on school property during the school day (without permission from the principal) is prohibited. If caught, this behavior will fall under the disruptive behavior of

the discipline grid found on Page 25. **Cell phones are prohibited from being used during the school day. If a student is caught using a cell phone during the course of the school day, the cell phone will be taken and brought to the office, where the principal will keep the phone for the remainder of the day. If a student is caught using the cell phone a second time, the principal has the authority to keep the phone for longer than just that school day.**

11. Video Phones

- **Drugs and Alcohol Abuse**

Any student who intentionally sells, gives, possesses, uses or is under the influence of illicit drugs, narcotics or alcohol in or on school property, including buses is prohibited. Discipline will follow the discipline grid found on Page 25. The appropriate law enforcement agencies for possible legal action will be notified.

- **Smoking and Chewing**

The use and/or possession of tobacco products, including chewing is prohibited. The policy applies on the way to and from school, on the bus, during lunch, at school activities on school property during the school day. The school day is defined as 8:15 am to 3:45 pm. Discipline will follow the discipline grid on Page 25.

### **DAMAGE TO SCHOOL PROPERTY**

Any intentional damage to school property will result in disciplinary action. Discipline will follow the discipline grid on Page 25. A large enough fine will be levied to cover the cost of the damages. Accidental damage to school property will also result in a fine to cover the replacement costs when, in the opinion of the principal, the accident was caused by student negligence.

### **DISRUPTION OF SCHOOL**

A student who by any reason disrupts the educational process of the Parkston schools will be sent to the principal's office, where the student will be dealt with by the principal. Discipline will follow the discipline grid. If a student should receive some suspension or detention, the parent or guardian will be notified. The guidance counselor will meet with the student if they do receive some suspension.

### **DISCIPLINE**

The following types of disciplinary action will be used at Parkston Jr./Sr. High School as administered by the principal. If there is disciplinary action and the counselor is involved, parents will be notified.

1. Extension of Schedule (Detention) – A form of discipline that detains a student outside of the normal school hours. The detention length will be determined by certified employees of the Parkston School District. Detention periods that are not attended by students will result in doubling of the detention time for each period missed. The detention period will be supervised by faculty members and/or administration. Students will be given a one (1) day notice before serving the detention. Students will be required to read an appropriate book or work on school assignments.
- **Saturday Detention:**
  - a. All detentions are assigned by the principal and will be served on Saturday morning.
  - b. Saturday morning detention supercedes any school sponsored activities that might take place on Saturday.
  - c. Students assigned detention must be there for the entire three hour period.
  - d. Detention hours are from 8:00 am to 11:00 am. Students who are tardy for detention will be sent home and the detention time will double.
  - e. Parents will always be notified when the student is assigned Saturday detention or is in violation of Saturday detention rules.
  - f. Students have two consecutive weeks to serve the detention. The week the detention is assigned and the following week. This will allow for plans that were made by the student or his/her parents prior to the detention being assigned. **NO EXCEPTIONS.**

- g. Short or long term, in or out of school suspension may be used in conjunction with Saturday detention.
  - h. Saturday detentions will be assigned for the following reason, but are not limited to these specific situations. Administration discretion will apply.
    1. 4<sup>th</sup> tardy
    2. Insubordination, poor behavior, disruptive behavior, written complaint for bad behavior on the bus
    3. Skipping class, tobacco use or possession, cheating, inappropriate language, matches or lighter
    4. Stealing
  - **Saturday Detention specified**
    - a. Students will be required to read an appropriate book or work on school assignments only. Magazines/newspapers will not be read during Saturday detention unless they are required by an assignment. Number “4” will be invoked if the student shows up to detention without a book or school work.
    - b. Students will not be allowed to chew gum, eat candy or food, drink pop or juice, talk (unless to instructor), sleep, lay head down, listen to radio or tapes, leave the study hall unless there is an emergency, play cards or games, watch TV, video tapes or movies unless assigned as class work.
    - c. A restroom break of 5 minutes will be allowed from 9:30 to 9:35.
    - d. Failure to comply with any of these rules will result in dismissal from detention for that day and the detention will be doubled.
  - **Skipping an assigned Saturday detention**
    - a. The student will be given 1 day of out of school suspension and 2 Saturday detentions for the first skip.
    - b. The student and his/her parents will be required to attend the next regularly scheduled Board of Education meeting to discuss student noncompliance or the second skip.
    - c. When a student has been assigned a third Saturday detention, the student, along with his/her parents or guardians will be required to appear at the next regularly scheduled Board meeting to discuss the behavior(s) causing Saturday detention.
2. In-School Suspension – In school suspension can only be given by the principal. This is done when a student has done more that what warrants a detention. The student can be placed in in-school suspension for one to three days. The student will be placed where he/she will be under supervision at all times. The student will be allowed to do his/her work with full credit.
3. Suspension from School – The principal may suspend a student from school for one to five days. The student will have to make up the work but will receive zeros for the work done. When a student is suspended, the principal shall attempt to reach the student’s parents or guardians to inform them of the school’s action and that their student is being sent home. If the student lives outside the city limits of Parkston and rides the bus, the parents or guardian will be requested to pick up the student. If the Student lives in town or drives to school, the parents will be notified of the time that the student will leave school.
4. Expulsion – If the principal decides to seek expulsion of a student he/she will notify the superintendent of schools and ask that a hearing date be set. This notification must be in writing and must state the reasons for expulsion.

## **DISCIPLINE GRID**

	Offenses	1 <sup>st</sup> Offense	2 <sup>nd</sup> Offense	3 <sup>rd</sup> Offense	4 <sup>th</sup> Offense	5 <sup>th</sup> Offense
<b>Class 1</b>	Tardies	4 <sup>th</sup> Unexcused tardy/semester Parental Contact Saturday Detention*	8 <sup>th</sup> Unexcused tardy/semester Parental Contact Saturday Detention*	12 <sup>th</sup> Unexcused tardy/semester Parental Contact ISS – 2 days	16 <sup>th</sup> Unexcused tardy/semester Parent Contact OSS – 2 days	17+ Unexcused tardy/semester Parental Contact OSS – 5 days
<b>Class 2</b>	Insubordination Poor Behavior Disruptive Behavior	Letter to Parent	Saturday Detention*	Saturday Detention*	ISS – 2 days	OSS – 2 days
	Inappropriate Behavior on the Bus	Letter to Parent	1 week off the bus	1 month off the bus	Off the bus for the remainder of the year	
<b>Class 3</b>	Skipping Class Tobacco Use or Possession Cheating Inappropriate Language Matches/Lighter	Saturday Detention*	Parental Contact ISS – 2 days	Parental Contact OSS - 2 days	Parental Contact OSS – 4 days	Parental Contact OSS – 6 days
<b>Class 4</b>	Stealing Under \$50	Saturday Detention* With Restitution***	Parental Contact With Restitution*** ISS – 2 days	Parental Contact With Restitution*** OSS - days	Parental Contact With Restitution*** OSS – 4 days	Parental Contact With Restitution*** OSS – 6 days
	Stealing \$51-\$250	Parental Contact With Restitution*** ISS – 2 days	Parental Contact With Restitution*** OSS – 3 days	Parental Contact With Restitution*** OSS – 5 days	Parental Contact With Restitution*** OSS – 10 days	Parental Contact With Restitution*** OSS – 10 days Referral for long term suspension
	Stealing Over \$251	Parental Contact With Restitution*** OSS – 3 days	Parental Contact With Restitution*** OSS – 5 days	Parental Contact With Restitution*** OSS – 10 days	Parental Contact With Restitution*** OSS – 10 days Referral for long term suspension	Parental Contact With Restitution*** OSS – 10 days Referral for long term suspension
<b>Class 5</b>	Violence, Fighting, Intimidation, Destruction of Property, Harassment, Blatant disrespect for staff, gang signs or symbols	Parental Contact With Restitution*** OSS – 3 days	Parental Contact With Restitution*** OSS – 5days	Parental Contact With Restitution*** OSS – 10days	Parental Contact With Restitution*** OSS – 10 days Referral for long term suspension	Parental Contact With Restitution*** OSS – 10 days Referral for long term suspension
	An attack	Parental Contact OSS – 10 days	OSS – 10 days Contact Parents Referral for Long term suspension or			

			expulsion			
<b>Class 6</b>	Alcohol Use or Possession	Parental Contact OSS – 3 days** Contact Police	Parental Contact OSS – 5 days Contact Police	Parental Contact Contact Police OSS – 10 days	Parental Contact Contact Police OSS – 10 days Referral for long term suspension or expulsion	
<b>Class 7</b>	Drug Use or Possession, Drug Paraphernalia	Parental Contact Contact Police OSS – 10 days Referral for long term suspension or expulsion****				
<b>Class 8</b>	Selling of distribution of drugs, bomb threat, endangering the life of others or weapons, assaulting staff	Parental Contact Contact Police OSS – 10 days Referral for long term suspension or expulsion				

\* If a student already has a Saturday Detention and receives an additional Saturday Detention they will be suspended out of school for 2 days.

\*\* This time could be cut in half if a student seeks dependency assessment and treatment from a certified chemical dependency counselor within 5 days at the cost to the student.

\*\*\* Without restitution, student may be referred to the School Board for further action

\*\*\*\* Referral for a possible long-term suspension will be made if student seeks a dependency assessment and treatment from a certified chemical dependency counselor with 10 days at student cost

Class 1 & 2 are recorded on the semester

Class 3 – 7 are recorded for the year

Any action that requires discipline that is not on the discipline grid will be handled on an individual basis by the administration.

### **CLASS DUES**

Students in the high school will be required to pay class dues in the amount determined by a majority vote of each class.

### **BICYCLES**

All bicycles should be parked on the west side of the building. Use the bicycle rack when possible. No one will use the bicycle during school hours unless you have permission from the principal. Please lock up your bicycles.

### **VISITORS**

**All visitors must report to the office.**

### **SCHOOL PHONE NUMBERS**

All phone calls on 928-3368 go through the superintendent's office and then forwarded to the appropriate building. There are times when the phone will be picked up in the high school or elementary first. We will then forward your call to the appropriate people. Parkston School – 928-3368.

### **WITHDRAWAL FROM SCHOOL**

Students will not officially be dropped from school until verbal or written permission to do so has been secured from the parents or guardians. Students will be dropped from school after missing 10 consecutive days of school.

### **CLUBS AND ORGANIZATIONS**

All clubs and organizations desiring to operate under the auspices of this school must secure a charter or organization from the student council before they can operate within the school, and also be sanctioned by the principal.

### **HAT POLICY**

There will be **NO** wearing of hats during the school day.

### **LASER LIGHT POLICY**

There will be no laser lights on school grounds, unless it is used for some education purpose in the classroom. The activities association has already prohibited them from any athletic activity.

### **RESTROOMS**

Restrooms are provided for only one purpose. Please use them for that purpose only and not for loitering, congregating or fighting. All students are to be courteous and considerate of any other student who may be using the facility. It is imperative that we all work to keep the restrooms clean and neat at all times. Students may go to the restrooms during class hours only by permission of the teacher. Only one person at a time is allowed the privilege. Anyone caught writing on the bathroom walls will be dealt with accordingly.

### **OFFICE ETIQUETTE**

The office area is a very busy place. It is very important to the smooth operation of the school and therefore must not be congested. Students are asked not to loiter in or near the offices. Students that do need to do business in the office are asked to do so and then move to another part of the building. Students are also asked not to enter the office when it is vacant. Under no circumstances will anyone take any item from the office without the expressed permission of the office personnel.

### **REPORT CARDS**

Report cards will be issued at the conclusion of each nine week period. The grade on the card will represent an average of all work done for that nine week period. Report cards will be mailed out unless they have been picked up at Parent-Teacher Conferences.

### **PARENT-TEACHER CONFERENCES**

Parent-teacher conferences will be scheduled at the middle or end of the 1<sup>st</sup> and 3<sup>rd</sup> nine week period.

### **DISCIPLINARY REPORTS AND DEFICIENCY REPORTS**

It may be necessary at times to notify parents by phone or by mail in regard to the conduct of their child at school or at school activities. At times it may be necessary for parents to come to the school for conferences with the principal, counselor, teachers and students.

At the end of each 4 ½ week period, deficiency reports will be sent out. They are sent out to any student that is receiving a D or F in a particular subject. A deficiency report can also be sent out on any student if the teacher feels that a student is not working up to his/her potential.

## GRADUATION

### CAPS AND GOWNS

Graduates of Parkston High School are required to wear cap and gowns at Commencement Exercises. If the class has money, it will be used to purchase the caps and gowns of the graduating seniors. All students must help raise the money for the class or they will have to purchase the cap and gown themselves. There may be an exception to this and it will be dealt with by the principal, class advisors and class officers.

### DRESS CODE FOR GRADUATION

The graduates are required to wear:

Girls: Dress pants or a dress and dress shoes.

Boys: Dress pants and acceptable shirts and dress shoes

There will be no wearing of anything that the administration feels is inappropriate for graduation.

### DIPLOMA

A diploma certifying the completion of the requirements for high school graduation will be awarded to each student having completed such requirements. Failure to meet these requirements will result in the student not being allowed to participate in the commencement exercises.

### HONOR GRADUATES

Honor students will be those students that have a cumulative GPA of 3.25 or above. For graduation purposes, honor point averages are computed at the end of the eighth semester.

## COMMUNICABLE DISEASE GUIDELINES

A number of communicable diseases may affect a school age population and/or staff. Some of these have a high degree of communicability. Some of life threatening in nature. Some are both.

<b>Disease and Incubation Period*</b>	<b>Rules for School Attendance</b>
Acquired Immune Deficiency Syndrome (AIDS) 6 months – five years	Determination will be made by the Advisory Committee as outlined in the Communicable Disease Policy
Chicken Pox 14-21 days	The student may attend school after all pox are dry and scabbed.
Cytomegalovirus (CMV) Salivary	The student may attend school. Precaution should be taken by contacts with immuno suppression as anti-cancer or organ transplant as well as anyone with suspected or known pregnancy. Good hand washing in all cases should eliminate risk of transfer of infection.
Fifth Disease (Erythema Infectiosum) 6-14 days	The student may attend school with physician's permission.
Giardiasis (Intestinal Protozoan Infection) 5-15 days or longer	The student may attend school if the student practices independent and hygienic bathroom skills. Other students may attend school after the third day of drug treatment. Good hand washing in all cases should eliminate risk of transfer of infection.
Herpes Simplex 2-12 days	The student may attend school during an active case if the student has the ability and practices personal hygiene precautions and the area of lesion is covered.
Impetigo – variable 4 –10 days Infectious Hepatitis 15-40 days Average 25 days	The student may attend school if treatment is verified and cover or dry. The student may attend school with physician's written permission and if the student has the ability to take appropriate personal hygiene precautions.
Measles (Red, Hard Rubeola, 7 day) 8-14 days	The student may attend school after a minimum of 7 days. Students who have had contact with measles may attend school if immunization is up to date.
Infectious Mononucleosis (Glandular Fever) 2-6 weeks	The student may attend school with Physician's permission. The student may need adjusted school days and activities.
Mumps 12-21 days	The student may attend school after swelling has disappeared.
Pediculosis (Lice, Crabs)	The student may attend school after treatment. After repeated infestation of the same student, the student may be excluded until all nits are removed.

Pink Eye (Conjunctivitis) 5-12 days	The student may attend school after the eye is clear, under treatment or with physician's written permission.
Plantar's Wart	The student may attend school. Students should not be permitted to walk barefoot.
Ring Worm (Scalp, Body, Athlete's Foot)	The student may attend school if the area is under treatment and covered. Restrict known cases of athlete's foot from pools and showers until under treatment.
Rubella (3-day German measles)	The student may attend school after a minimum of 4 days. Prevent exposure of pregnant women.
Scabies (7-year Itch, mites)	The student may attend school after treatment.
Streptococcal Infections (Scarlet Fever, Scranlentina, Strep Throat) 1-3 days	The student may attend school 24 hours after initiating oral antibiotics therapy and clinically well.

A communicable and chronic disease should be reported to Health Services

\*Time interval between initial contact with an infectious agent and the first sign or symptom of the disease.

### **STUDENT GRIEVANCE**

A grievance is defined as a complaint lodged by a student with a member of the staff or administration alleging one or more of the following unfair practices: 1) that a school rule is unfair, 2) that a school rule or regulation discriminates between students based on sex, age, race, color, religion, national origin, or handicap, 3) that an unfair procedure has been used in arriving at a punishment. Grievances are processed through 3 steps: a) to the principal, b) to the superintendent, c) complaints that remain unresolved following any action of the superintendent may be referred in writing to the School Board for review. The Board's decision will be final unless an appeal is requested. On all three levels an informal conference is to be held within five days of the date of filing of the complaint so that no student's complaint shall consume more than 15 days of time in all. The burden of proof is upon the student to show that rule is unfair, is discriminatory, or that an unfair procedure (lack of due process) has been perpetrated. The final resolution of the grievance is to be in writing and designed to provide the student with a basis for resolution of the program as originally stated in the complaint.

### **STUDENT GRIEVANCE PROCEDURE**

If a student has a grievance, he/she should present it in writing to:

- Level One: to their school principal for an information conference discussion and resolution of said grievance.
- Level Two: If a student is not satisfied with the resolution made at level one, he/she may appeal to the superintendent for an informal conference, discussion and resolution of said grievance.
- Level Three: Complaints that remain unresolved following any action of the superintendent may be referred in writing to the School Board for review. The board's decision will be final unless an appeal is requested.

### **STUDENT GRIEVANCE FORM**

A grievance is defined as a complaint in writing presented by a student to the school staff/authorities alleging one or more of the following:

- A. That a rule is unfair: and or
- B. That rule in practice discriminates against or between students based on sex, age, race, color, Religion, national origin, handicap: and/or
- C. That school personnel used an unfair procedure in assessing a form of punishment against a student.

### **COMPLAINT FORM**

Check One Blank

Date \_\_\_\_\_

Level 1 \_\_\_\_\_ Principal

Level 2 \_\_\_\_\_ Superintendent



Level 3 \_\_\_\_\_ School Board

I, \_\_\_\_\_, hereby file a grievance complaint to \_\_\_\_\_  
\_\_\_\_\_. My grievance is based on A. \_\_\_\_\_, B. \_\_\_\_\_, C. \_\_\_\_\_ above.

(More than one blank may be checked)

Specifically, my grievance is that \_\_\_\_\_  
\_\_\_\_\_  
\_\_\_\_\_

I hereby petition for a hearing on my grievance at the convenience of the school's personnel, but in no event later than five school days from the date of this petition.

\_\_\_\_\_  
Student's Signature(s)

The student may be represented at the conference by an adult, but the student(s) must be present to elaborate on his/her grievance at the given time and place of the conference. Failure to appear at the appointed time and place effectively waives the student's right to the conference provided by the school, unless extenuating circumstances make it impossible for the student to appear.

**SCHOOL'S RECORD**

Date Received \_\_\_\_\_ Date of Conference \_\_\_\_\_  
Place of Conference \_\_\_\_\_ Time of Conference \_\_\_\_\_  
Comments: \_\_\_\_\_  
\_\_\_\_\_

Resolution: \_\_\_\_\_  
\_\_\_\_\_

\_\_\_\_\_  
Signature of School Representative

**COMPONENTS OF A GRIEVANCE PROCEDURE**

- I. Provisions related to the initiation of grievance
  - A. The definition of who may grieve
  - B. The definition of what shall constitute a grievance
  - C. The stipulation of time limits for the initiation of grievances
  - D. The stipulation of the manner or form in which grievances shall be initiated
  - E. The specification of any assistance available to grievances for the initiation/presentation of a grievance
- II. Provisions related to the processing of grievances
  - A. The number and levels of steps for grievance processing
  - B. The form of grievance presentation or processing at each step
  - C. Requirements for notification of involved parties at various phases of the grievance process
  - D. Timelines governing the various actions or steps within the grievance process
  - E. Procedures which shall govern the conduct of grievance meetings or hearings at any step of the grievance process, e.g.
    - a. the minimum time allocated for the grievance hearing
    - b. the time allocated to each party
    - c. the right of each party to representation
    - d. the moderation of hearings
    - e. the right to confidential or public grievance meetings or hearings
    - f. procedures for recording the meeting or hearing
  - F. Requirements for the filing of submission of written information by the grievant of the respondent
  - G. The specification of the forms which grievance decisions shall take at each step
  - H. The roles and/or the selection of persons involved in grievance processing
- III. Provisions related to the basic procedural rights of the parties to the grievance
  - A. The grievance's right of appeal

- B. The right of all parties to impartial grievance decision-makers
- C. The access of grievance to relevant agency/institutional records
- D. Protection of grievance from harassment and retaliation
- E. Confidentiality of grievance proceedings

**PARENT GRIEVANCE**

A grievance is defined as a complaint lodged by a parent with a member of the staff or administration alleging one or more of the following unfair practices: 1) that a school rule is unfair, 2) that a school rule or regulation discriminates between students based on sex, age, race, color, religion, national origin or handicap, 3) that an unfair procedure has been used in arriving at a punishment. Grievances are processed through 3 steps: a) to the principal, b) to the superintendent, c) complaints that remain unresolved following any action of the superintendent may be referred in writing to the School Board for review. The Board’s decision will be final unless an appeal is requested. On all three levels an informal conference is to be held within five days of the date of filing of the complaint so that no parent’s complaint shall consume more than 15 days time in all. The burden of proof is upon the parent to show that rule is unfair, is discriminatory, or that an unfair procedure (lack of due process) has been perpetrated. The final resolution of the grievance is to be in writing and designed to provide the parent with a basis for resolution of the program as originally stated in the complaint.

**PARENT GRIEVANCE PROCEDURE**

If a parent has a grievance, he/she should present it in writing to:

- Level One: to their school principal for an information conference discussion and resolution of said grievance
- Level Two: If a parent is not satisfied with the resolution made at level one, he/she may appeal to the superintendent for an informal conference, discussion and resolution of said grievance.
- Level Three: Complaints that remain unresolved following any action of the superintendent may be referred in writing to the School Board for review. The board’s decision will be final unless an appeal is requested.

**PARENT GRIEVANCE FORM**

A grievance is defined as a complaint in writing presented by a parent to the school staff/authorities alleging one or more of the following:

- A. That a rule is unfair and/or inappropriately applied, or
- B. That a rule in practice discriminates against or between students and/or parents based on gender, age, race, color, religion, national origin, or handicap, and/or
- C. That school personnel used an unfair procedure in assessing a form of punishment against a student.

**COMPLAINT**

Check One Blank

Date \_\_\_\_\_

Level 1  Principal

Level 2  Superintendent

Level 3  School Board

I, \_\_\_\_\_, hereby file a grievance complaint to \_\_\_\_\_.  
My grievance is based on A. \_\_\_\_\_, B. \_\_\_\_\_, C. \_\_\_\_\_ above.

(More than one blank may be checked)

Specifically, my grievance is that \_\_\_\_\_  
\_\_\_\_\_

I hereby petition for a hearing on my grievance at the convenience of the school’s personnel, but in no event later than five school days from the date of this petition.

\_\_\_\_\_  
Parent’s signature(s)

The parent or representative may be present to elaborate on his/her grievance at the given time and place of the conference. Failure to appear at the appointed time and place effectively waives the parent's right to the conference provided by the school, unless extenuating circumstances make it impossible for the parent to appear.

**SCHOOL'S RECORD**

Date Received \_\_\_\_\_ Date of Conference \_\_\_\_\_  
Place of Conference \_\_\_\_\_ Time of Conference \_\_\_\_\_  
Comments: \_\_\_\_\_  
\_\_\_\_\_  
Resolution: \_\_\_\_\_  
\_\_\_\_\_

\_\_\_\_\_  
Signature of School Representative

**PARKSTON SCHOOL DISTRICT MEDICATION POLICY**  
**ADMINISTERING MEDICINES TO STUDENTS**

Parents are encouraged to give medications at home whenever possible. **For those cases where it is not possible to administer the medication at home, school district will train building principals, the elementary and secondary principal's administrative assistants and the High School office/study hall aide, who will administer medications in school. Furthermore, the district will contract with the Community Health Nurse to oversee the program and to regularly review procedures.** If it is necessary to administer medications to students during school hours, the following regulations will be observed.:

1. Medication to be administered by school personnel must be provided in labeled container from the pharmacy or physician with the student's name, date, medication name, dosage and frequency to be given.
2. An official consent form must be signed by a parent/guardian. The form will specify what dose the school is responsible for administering, i.e. the noon dose. Medication will not be given without this written permission. Medication doses other than the dose listed on the consent form will not be administered, i.e. missed morning doses.
3. There will be a consent form for each medication.
4. A parent/guardian or designated adult **MUST** deliver to the school all medications including refills to be administered by school personnel.
5. All medications brought to the school will be counted and documented on **MEDICATION COUNT** form with two verifying signatures.
6. If there is an increase or decrease in medication, **only the supervisor of the medication administration program, the community health nurse**, can take verbal or telephone order from the health care provider. A new prescription label must be received within 24 hours.
7. If there is a change of medication (different medication), a new consent form must be completed.
8. Over the counter medications will be given only when prescribed by a physician and labeled by a pharmacy with name, date, medication name, dosage and time schedule.
9. Teachers will be notified of a student taking medication using a **Medication Notification** slip. This will include student's name and what time to send the student to the office for medication.
10. **Medication Administration Logs** will be utilized to document medication-administration. The person delegated to give the medication will sign and time the log.
11. All medications must be stored in a locked cabinet.
12. Medications can safely be administered up to 1/2 hour before or after prescribed time.
13. All consent forms and log sheets will be kept for one year past the last administered date.
14. If a student needs to carry an inhaler(s) a consent form must be completed with the parent indicating approval of self-administering the medication. The inhaler needs to be properly labeled. **A Medication Administration Log** will not be maintained.
15. Students will be responsible for reporting to the office for taking medication.
16. Parents are responsible for refills. Parents are urged to keep track of time frame for needed refills.

17. Parkston Public Schools will not be held responsible for any medication self-administered with or without our knowledge.
18. If medication is for emergency use only, such as a bee sting kit, parents must demonstrate proper procedure on the use of the medication kit and leave complete instructions provided by the physician for administration.
19. Students at Parkston High School will be allowed to self administer prescription and non-prescription medications after their parents have signed a waiver and the student has demonstrated the ability to administer such. Exemptions to this will be:
  - Controlled substances such as Ritalin and Dexedrine
  - Parental request to have school personnel store and administer or assist with administration of medication
  - IEP of students specifies storage and administration of medication by school personnel Health Services recommends that medication be stored and administered by school personnel for a specific student.

### **Junior High School**

All the above rules apply with two exceptions:

1. Where parents/guardians hold student responsible, refills may be sent with the student to school
2. Students may have, in their possession, a daily dose of non-prescription medication, such as aspirin, decongestant, etc. This medication should be in the original container and labeled with the student's name.

### **High School**

1. Students at Parkston High School will be allowed to self-administer prescription and non-prescription medications. Exemptions to this will be:
  - Controlled substances such as Ritalin and Dexedrine.
  - Parental request to have school personnel store and administer or assist with administration of medication
  - IEP of student specifies storage and administration of medication by school personnel
  - Health services recommends that medication be stored and administered by school personnel for a specific student.
2. Medications stored and administered by school personnel will follow rules of the Parkston School District's Medication policy.
3. Students will be allowed to transport medication refills to school
4. All medications (prescription and non-prescription) in a student's possession should be in the original container and labeled with the student's name.
5. The principal or designee maintains the right to discontinue the student's privilege of self-administering medication if the student is abusing the intent of the policy.

## **PARKSTON SCHOOL DISTRICT 33-3**

### **REQUEST AND AUTHORIZATION FOR MEDICATION/TREATMENT**

Parents are encouraged to give medications at home whenever possible. **For those cases where it is not possible to administer the medication at home, school district will train the building principals, the elementary and secondary principals' administrative assistants and the HS office/study hall aide, who will administer medication in school. Furthermore, the district will contract with the Community Health Nurse to oversee the program and to regularly review procedures.** If it is necessary to administer medications to students during school hours the following regulations will be observed:

1. A parent/guardian or designated adult must deliver to the school all medications including refills to be administered by school personnel.
2. Medication to be administered must be prescribed by a licensed medical professional. The school by contact the professional as necessary.
3. Medication to be administered by school personnel must be provided in the prescription container with the prescription attached. Medication improperly packaged or labeled will not be administered.
4. Parents or guardians must provide the information requested below and sign the form granting the school permission to administer the medication.

To be completed by parent or guardian:

I request and authorize officials at

\_\_\_\_\_ School to supervise the below stated medication and dosage.

Student's name \_\_\_\_\_

Medication \_\_\_\_\_

Dosage and time \_\_\_\_\_

Method (oral, ear drops, etc.) \_\_\_\_\_

Possible side effects or adverse reactions \_\_\_\_\_

The student being treated for \_\_\_\_\_

I understand the medication shall provided in a bottle labeled by the pharmacy to include the student's name, medication and strength, dosage and time medication is to be taken, and physicians name. I understand that district personnel are rendering a service and will administer the medication only in accordance with the instructions on the label. I understand that the school district and individuals involved will not be liable from any adverse effects of the medication. I understand that the school may contact the prescribing professional regarding the medication and/or its effects.

\_\_\_\_\_ Initial for consent to carry and self administer inhaler.

Signed (parent or guardian) \_\_\_\_\_ Date \_\_\_\_\_

## **CIVIL AND LEGAL RIGHTS AND RESPONSIBILITIES (GENERAL)**

### **EDUCATION**

Each student has the right to an education and he/she also has the responsibility not to interfere with or threaten the education of others by his/her actions.

Each student has the responsibility to attend school regularly and to abide by the policies and regulations of the school.

Students have the right to seek changes in school policies and regulations in an orderly manner by utilizing those channels provided for this purpose.

### **EXPRESSION**

The primary liberties in a student's life have to do with the processes of inquiry and learning, acquiring and imparting knowledge, and exchanging ideas. These processes require that students have the right to express opinions, to take stands, and to support causes either publicly or privately. There should be no unlawful interference by the school with these liberties or with the student's access to or expression of controversial points of view.

### **SPEECH**

Every student has the right to express his/her opinion wither verbally or symbolically as long as he/she does not infringe upon the rights of others.

As an intellectual being, every student has a right to search vigorously for truth by examining opposing ideas and to espouse and express in an orderly manner whatever views command the assent of his/her mind. Where soundness of his/her position can neither be penalized academically for holding these views.

A student's responsibility must include personal concerns for the effect of the spoken word or symbolic expression on the personal reputation of others, and a student has the right to have his/her own personal reputation protected accordingly. Consequently, personal attacks and obscenities are prohibited.

## **CO-CURRICULAR AND EXTRA-CURRICULAR OFFERINGS AND LETTERING GUIDELINES**

### **BASKETBALL: BOYS**

To letter in boys basketball a player must play in 18 quarters of varsity games. To play in any part of a quarter constitutes one quarter. A letter may also be given to anyone at the coach's discretion.

### **BASKETBALL: GIRLS**

To letter in girls basketball a player must play in 18 quarters of varsity games. To play in any part of a quarter constitutes one quarter. A letter may also be given to anyone at the coach's discretion.

### **FOOTBALL**

Letter will be earned by a junior or senior based on team practices, completing an entire season, and by giving outstanding contributions to the football team. Freshmen and sophomores will earn a letter based on playing in eight quarters of varsity games.

### **TRACK: BOYS**

A letter will be awarded to an athlete for earning three (3) points in a major meet. A major meet will be any meet other than a dual or triangular.

### **TRACK: GIRLS**

A letter will be awarded to an athlete for earning three (3) points in a major meet. A major meet will be any meet other than a dual or triangular.

### **WRESTLING**

A major letter will be awarded to an athlete that places in a varsity tournament and/or wrestle in two (2) or more varsity duals, triangular or quads. A letter may also be given to wrestlers at the coach's discretion.

### **GOLF: BOYS AND GIRLS**

A letter will be awarded to an athlete that contributes a score that is counted towards team total in placing in a varsity match or regional match.

### **CHEERLEADING**

A letter will be awarded to a cheerleader that is a member of one of the varsity squads and takes part in practices, meetings and conducts themselves in compliance with the rules of cheerleading and the school.

### **VOLLEYBALL**

A letter will be awarded to an athlete that is a member of the varsity volleyball squad and has played in two (2) or more matches and has contributed consistently in practices and games.

### **7<sup>TH</sup> AND 8<sup>TH</sup> GRADE ATHLETICS**

The Athletic Director makes all the 7<sup>th</sup> and 8<sup>th</sup> grade arrangements for athletic activities.

Suggest no travel over 50 miles one way.

The junior high season will usually run in conjunction with the high school season.

### **FCCLA**

Seniors: In order to earn a scholarship you must have participated in enough FCCLA activities to receive 175 points. Scholarships are awarded to 4-year members only. Scholarships are awarded based on recommendations of a designated committee.

Members must earn 125 points to letter.

## **NATIONAL HONOR SOCIETY SELECTION PROCESS**

1. There will be a creation of a Faculty Council.

2. Students' academic records will be reviewed to determine scholastic eligibility. A student must have a 3.25 GPA to be academically eligible for consideration.
3. Students who are eligible scholastically will be notified and told that further consideration for selection to the National Honor Society Chapter, will be after they complete the Student Activity Information Form.
4. If additional faculty input would be beneficial, all faculty members could be invited to make comments on candidates. However, the actual selections must be made by the five appointed members of the faculty council. It is no longer permissible to make an entire faculty vote.
5. The Student Activity Information Form will be reviewed by the faculty council, along with any other verifiable information about each candidate. Some faculty councils may wish to interview candidates personally. Candidates receiving a majority vote of the faculty council will be inducted into the chapter. A point system is used to evaluate candidates, the cut off point is determined prior to reviewing candidates.

## CHAPTER OF THE NATIONAL HONOR SOCIETY

\_\_\_\_\_  
(Chapter Name)

### SAMPLE STUDENT ACTIVITY INFORMATION FORM

(Not an application form)

Directions: Please complete all sections. Do not be modest. Every bit of information can be used by the faculty council to assist with the selection process. Completion of the form does not guarantee selection.

I. Administrative Information (Please type or print)

Name: \_\_\_\_\_

Other Information as required:

II. Co-curricular Activities: \_\_\_\_\_

List all activities in which you have participated during high school. Include clubs, teams, Musical groups, etc., and major accomplishments in each.

Activity	9	10	11	12	Accomplishments

III. Leadership Positions: \_\_\_\_\_

List all elected or appointed leadership positions held in school, community, or work activities. Only those positions in which you were directly responsible for directing or motivating others should be included. For example, elected student body, class, or club officer; committee chairperson; team captain; newspaper editor; work area manager; or community leader.

Leadership Position	9	10	11	12	Activity or organization

IV. Community Activities: \_\_\_\_\_

List community activities in which you have participated and note any major accomplishments in each. These should be any activities outside of school in which you participated for the betterment of your community. For example: church groups, clubs sponsored outside the school, Boy or Girl Scouts, volunteer groups, or community art endeavors.

Community Activity	9	10	11	12	No. of Hours/Wk.	Major Accomplishments	Signature of Adult Sponsor

V. Work Experience, Recognition, and Awards: \_\_\_\_\_

List below any job experiences, honor, or recognition, that you have received which support your bid to be selected for membership in the National Honor Society. Work experience may be paid or volunteer.

Job Recognition or Award	9	10	11	12	Group or Activity, Number of Hours Spent on Job or Volunteer Activity

Write a paragraph about community service and any other information the student feels is important about themselves.

### SENIOR PRIVILEGES

**GUIDELINES**

1. Seniors must attend all classes in which they are enrolled but are not required to attend study halls.
2. The maximum number of free periods for senior privileges are one and a noon period.
3. Seniors must be in class on time. The first tardy they receive will be a warning. The second tardy they receive will be the loss of senior privileges for 3 weeks. The third tardy will result in loss of senior privileges for the rest of the semester.

**VEHICLES**

- a. Seniors are permitted to drive their vehicle during the school day.
- b. No underclassmen may ride around with seniors during school time, including lunch time.
- c. Students must adhere to local traffic regulations.
- d. Students will not drive around the school during school time.
4. Any use of alcohol or tobacco during the school day (8:15-3:45) is a violation of state law and school policy. Students will be subject to the same punishment as any other part of the school day, plus will automatically lose senior privileges for the remainder of the school year.
5. Seniors may go to the front of the lunch line and eat first.



6. Students who want to study during a free period must use the supervised designated area set by the principal. They may not sit in the hallways between classes. They may leave the building or be in the supervised designated area, but they may not wander around the building.
7. To receive senior privileges, seniors must: **Must not have a grade of D- or an F. Grades will be monitored on a weekly basis. If a student has a grade of a D- or an F, they will lose the privilege for at least one week. For figuring eligibility and privileges, we operate from Monday morning 8:30 to Monday morning 8:30.**

**BEGINNING WITH SPRING SEMESTER 2000, ANY STUDENT FAILING A COURSE AND WISHING TO TAKE THE MAKE-UP WORK BY CORRESPONDENCE WILL NOT BE ALLOWED SENIOR PRIVILEGES. MAKE-UP WORK DONE IN THE CLASSROOM WILL NOT AFFECT SENIOR PRIVILEGES.**

**IF A STUDENT MISSES A TOTAL OF 10 DAYS OF SCHOOL DURING THAT SEMESTER, THEY WILL LOSE THEIR SENIOR PRIVILEGES. ALSO THE NUMBER OF TIMES A STUDENT MAY MISS A PARTICULAR CLASS CANNOT EXCEED 10 OR THEY WILL LOSE THEIR SENIOR PRIVILEGES.**

### **FERPA FACT SHEET – FAMILY EDUCATIONAL RIGHTS AND PRIVACY ACT OF 1974 (FERPA)**

The Family Educational Rights Act (FERPA) is a federal law designed to protect the privacy of a student's education records. The law applies to all schools that receive funds under an applicable program of the U.S. Department of Education.

FERPA gives parents certain rights with respect to their children's education records. These rights transfer to the students, or former student, who has reached the age of eighteen or is attending any school beyond the high school level. Students and former students to whom the rights have transferred are called eligible students.

Parents or eligible students have the right to inspect and review all of the student's education records maintained by the school. Schools are not required to provide copies of materials in education records unless, for reasons such as great distance, it is impossible for parents and eligible students to inspect the records. School may charge a fee for copies.

Parents and eligible students have the right to request that a school correct records believed to be inaccurate or misleading. If the school decides not to amend the record, the parent or eligible student then has the right to a formal hearing. After the hearing, if the school still decides not to amend the record, the parent or eligible student has the right to place a statement with the record commenting on the contested information in the record.

Generally, the school must have a written permission from the parent or eligible student before releasing any information from a student's record. However, the law allows schools to disclose records, without consent, to the following parties:

- School employees who have a need-to-know
- Other school to which a student is transferring
- Certain government officials in order to carry out lawful functions
- Appropriate parties in connection with financial aid to a student
- Organizations doing certain studies for the school
- Accrediting organizations
- Individuals who have obtained court orders or subpoenas
- Persons who need to know in case of health and safety emergencies
- State and local authorities, within a juvenile justice system, pursuant to specific state laws

School may also disclose, without consent, "directory" type information such as a student's name, address, telephone number, date and place of birth, honors and awards, and dates of attendances. However, school must tell parents and eligible students about directory information and allow parents or eligible students a reasonable amount of time to request that the school not disclose directory information about them.

School must notify parents and eligible students of the rights under this law. The actual means of notification (special letter, inclusion in a PTA bulletin, student handbook, or newspaper article) is left to the discretion of each school. For additional information or technical assistance, call (202) 260-3887 or TDD 260-8956, or contact:

Family Policy Compliance Office  
U.S. Department of Education  
600 Independence Avenue, S.W.  
Washington, D.C. 20202-460

## **PARKSTON SCHOOL DISTRICT** **GUIDELINES FOR EXTRA-CURRICULAR PARTICIPATION**

The Board of Education has set up a policy on rules and regulations for extra-curricular participants so that all interested parties have knowledge of said rules at Parkston High School. Below you will find listed what the school board feels are a reasonable set of rules that participating students should and will be required to follow: These guidelines apply to: All Sports, Cheerleading, Band, Chorus, Play, Journalism, FBLA, Art Club, National Honor Society and FCCLA. (Band and Chorus season will be based on a 9-week period of time.)

Guidelines for all Extra-Curricular Participants are in effect from the first practice in August until participants return from State Track Meet.

### **NO GAPS BETWEEN SEASONS**

**Guideline 1: Participants shall not use or possess illegal drugs, or drug paraphernalia and/or commit any type of felony.**

### **1<sup>st</sup> Offense – Will follow SDCL 13-32-9**

### **SDCL 13-32-9 SUSPENSION FROM EXTRACURRICULAR ACTIVITIES FOR CONTROLLED SUBSTANCE VIOLATIONS.**

Section 1. That § 13-32-9 be amended to read as follows: 13-32-9. Any person adjudicated, convicted, the subject of an informal adjustment or court-approved diversion program, or the subject of a suspended imposition of sentence or suspended adjudication of delinquency for possession, use, or distribution of controlled drugs or substances or marijuana as defined in chapter 22-42, or for ingesting, inhaling, or otherwise taking into the body any substances as prohibited by § 22-42-15, is ineligible to participate in any extracurricular activity at any secondary school accredited by the Department of Education for one calendar year from the date of adjudication, conviction, diversion, or suspended imposition of sentence. The one-year suspension may be reduced to sixty school days if the person participates in an assessment with a certified chemical dependency counselor or completes an accredited intensive prevention or treatment program. If the assessment indicates the need for a higher level of care, the student is required to complete the prescribed program before becoming eligible to participate in extracurricular activities. Upon a subsequent adjudication, conviction, diversion, or suspended imposition of sentence for possession, use, or distribution of controlled drugs or substances or marijuana as defined in chapter 22-42, or for ingesting, inhaling, or otherwise taking into the body any substances as prohibited by § 22-42-15, by a court of competent jurisdiction, that person is ineligible to participate in any extracurricular activity at any secondary school accredited by the Department of Education. Upon such a determination in any juvenile court proceeding the Unified Judicial System shall give notice of that determination to the South Dakota High School Activities Association and the chief administrator of the school in which the person is participating in any extracurricular activity. The Unified Judicial System shall give notice to the chief administrators of secondary schools accredited by the Department of Education for any such determination in a court proceeding for any person eighteen to twenty-one years of age without regard to current status in school or involvement in extracurricular activities. The

notice shall include name, date of birth, city of residence, and offense. The chief administrator shall give notice to the South Dakota High School Activities Association if any such person is participating in extracurricular activities.

Upon placement of the person in an informal adjustment or court-approved diversion program, the state's attorney who placed the person in that program shall give notice of that placement to the South Dakota High School Activities Association and chief administrator of the school in which the person is participating in any extracurricular activity.

**As used in this section, the term, extracurricular activity, means any activity sanctioned by the South Dakota High School Activities Association.**

**REVISED 2006 LEGISLATIVE SESSION  
AMENDED 2010 LEGISLATIVE SESSION**

**The cost assessment and treatment if necessary is the responsibility of the parent/guardian.**

The Parkston School District is willing to assist students who seek help for a chemical dependency problem. Students with no identified violations will not be penalized if they voluntarily enter a treatment program and abstain from using any substances which are in violation of this policy. If while in this program, they violate the rules, they will be penalized the same as any other student.

**The cost assessment and treatment if necessary is the responsibility of the parent/guardian.**

**Guideline 2: Participants shall not use or possess alcohol, tobacco, or mood-altering substance, such as but not limited to steroids and inhalants.**

*a. Applies specifically to all sports, cheerleading, band, chorus, play and journalism participants.*

**1<sup>st</sup> Offense** – Participants will be withheld from competition from that sport or activity for a minimum of (10) calendar days including at least two (2) regularly scheduled event in that sport or activity. If the season ends and the suspension is not completed, the remaining penalty will then be served when the next seasonal activity in which the student participates begins. If the student is not currently participating in any seasonal activity, then the entire penalty will be served when the next activity in which the student participates begins. The penalty carries over from one (1) year to the next, if necessary to complete the penalty.

**STUDENTS MUST PRACTICE.**

**2<sup>nd</sup> Offense – for use or possession of tobacco** Participants will be with held from competition in that sport or activity for a minimum of (20) calendar days including at least four (4) regularly scheduled events in that sport or activity.

**2<sup>nd</sup> Offense – for use or possession of Alcohol or other mood-altering substance** Participants will be withheld from competition that sport or activity for a minimum of (20) calendar days including at least four (4) regularly scheduled events in the sport or activity and the person must participates in an assessment with a certified chemical dependency counselor or completes an accredited intensive prevention or treatment program. If the assessment indicates the need for a higher level of care, the student is required to complete the prescribed program before becoming eligible to participate in extracurricular activities. This assessment will be at the cost of the participant. **SAME CARRY OVER AS THE 1<sup>ST</sup> OFFENSE**

**The cost assessment and treatment if necessary is the responsibility of the parent/guardian.**

**3<sup>rd</sup> Offense** – Participants who commit a 3<sup>rd</sup> offense will be prohibited from participating in all sports, cheerleading, band, chorus, plays and journalism for one (1) calendar year.

The Parkston School District is willing to assist students who seek help for a chemical dependency problem. Students with no identified violations will not be penalized if they voluntarily enter a treatment program and abstain from using any substances which are in violation of this policy. If while in this program, they violate the rules, they will be penalized the same as any other student.

**The cost assessment and treatment if necessary is the responsibility of the parent/guardian.**

b. *Applies specifically to student organization to include FBLA, Art club, National Honor Society, and FCCLA participants.*

**1<sup>st</sup> Offense** – Students will be withheld from an club-out-of school activities that takes place during the 9 week period in which the student committed the offense.

**2<sup>nd</sup> Offense for possession or use of tobacco** – Student will be with held from any club out-of-school activity that takes place during the 9 week in which the student committed the offense and the next 9 week period.

**2<sup>nd</sup> Offense for possession or use of alcohol or other mood-altering substance.** Student will be withheld from any club out-of-school activity that takes place during the 9 week in which the student committed the offense and the next 9 week period. The suspension will carry over to the next school year if the offense is committed during the last 9-week period of the school year, and the person must participates in an assessment with a certified chemical dependency counselor or completes an accredited intensive prevention or treatment program. If the assessment indicates the need for a higher level of care, the student is required to complete the prescribed program before becoming eligible to participate in extracurricular activities.

**The cost assessment and treatment if necessary is the responsibility of the parent/guardian.**

**3<sup>rd</sup> Offense** – Student will be prohibited from participating in all club activities for one (1) calendar year.

The Parkston School District is willing to assist students who seek help for a chemical dependency problem. Students with no identified violations will not be penalized if they voluntarily enter a treatment program and abstain from using any substances which are in violation of this policy. If while in this program, they violate the rules, they will be penalized the same as any other student.

**The cost assessment and treatment if necessary is the responsibility of the parent/guardian.**

**Guideline 3: Participants shall observe a curfew of 11:00 p.m. on weekdays (Sunday through Thursday) and 1:00 a.m. on weekends (Friday and Saturday). Curfew will be observed only during each activity season. (Activity Directors may deviate from the above stated curfew at their own discretion.)**

a. *Applies specifically to all sports, cheerleading, band, chorus, play and journalism participants.*

**1<sup>st</sup> Offense** – Probation

**2<sup>nd</sup> Offense** - Participants will be removed for five (5) calendar days including (1) regularly scheduled event in that sport or activity. **STUDENT MUST PRACTICE.**

**3<sup>rd</sup> Offense** – Participants will be removed from the activity for the remaining days of the season.

b. *Applies specifically to student organizations to include FBLA, Art Club, National Honor Society, and FCCLA participants:*

**Curfew** will be imposed according to state guidelines for the individual organizations.

**Guideline 4: Students are encouraged to attend all practice sessions. Director's need not accept any Unexcused Absence. Excused Absence would be an illness or injury of the participant and/or church, school, and family reason. Excuses must be given to the Director before practice – no missing practice and then getting an excuse from your parents.**

*Applies to all sports, cheerleading, band, chorus, play, journalism, FBLA, Art Club, National Honor Society, and FCCLA participants.*

**Directors** will decide the consequences for violation of this guideline.

**Guideline 5:** All Activity Directors may have other rules and regulations in addition to the above guidelines for their sport or activity.

*Applies to all sports, cheerleading, band, chorus, play, journalism, FBLA, Art Club, National Honor Society and FCCLA participants.*

**Guideline 6:** The above rules apply if the report is made by adult who witnessed a violation by the participants and is willing to testify.

*Applies to all sports, cheerleading, band, chorus, play, journalism, FBLA, Art Club, National Honor Society, and FCCLA participants.*

**Guideline 7:** Training rules governing the time from the day after and the State Track Meet until the first day of practice in August shall be as follows: Any student who is adjudicated or a drug-related offense, or any felony conviction during the summer months, shall serve the above listed penalty during their first activity season the following school year. These offenses would include, but not limited to DUI and possession or sale of drugs or drug paraphernalia. This would serve as a student’s “first offense” for the coming school year.

*Applies to all sports, cheerleading, band, chorus, play, journalism, FBLA, Art Club, National Honor Society, and FCCLA participants.*

\_\_\_\_\_ Student

\_\_\_\_\_ Parent/Guardian

**TRAINING RULES FORM**

I have read the training rules and understand all the rules and regulations. I realize the faculty and administration are here to help me in any way necessary. I will feel free to come to the faculty and/or administration with any problems.

**PARENT/GUARDIAN SIGNATURE** \_\_\_\_\_

**PARENT/GUARDIAN SIGNATURE** \_\_\_\_\_

**STUDENT SIGNATURE** \_\_\_\_\_

**DATE** \_\_\_\_\_

Revised: 11/8/2010

# **STUDENTS: INTERNET AND ELECTRONIC MAIL ACCEPTABLE USE POLICY**

## **PARKSTON PUBLIC SCHOOL ACCEPTABLE USE POLICY**

### **INTERNET AND ELECTRONIC MAIL**

#### **PERMISSION FORM**

**Please read the following carefully before signing this document. This is a legally binding document.**

The Internet is an electronic highway connecting thousands of computers all over the world and millions of individual subscribers. These guidelines are provided so that you are aware of the responsibilities you are about to acquire. In general, this requires efficient, ethical and legal utilizations of the network resources. If a Parkston Public School user violates any of these provisions, his or her current access will be terminated in the future and indicate the party (parties) who signed has (have) read the terms and conditions carefully and understand(s) their significance.

#### **INTERNET – TERMS AND CONDITIONS**

**1. Acceptable Use** – The purpose of providing Internet and Electronic Mail (E-Mail) through State K-12 E-Mail System is to enable students to explore thousands of libraries, databases and bulletin boards while exchanging messages with Internet users throughout the world.

The use of the Internet and E-Mail must be in support of education and research consistent with the educational objectives of the Parkston School District. Use of other organization's networks or computing resources must comply with the rules appropriate for that network. Transmission of any material in violation of an U.S., or state regulation is prohibited. This includes, but is not limited to: copyrighted material, threatening, obscene or lewd material, or material protected by trade secret. Use for product advertisement, commercial purposes, or political lobbying is also prohibited.

**Students will not use any mass e-mailing lists created by district personnel to send out an e-mail unless the e-mail has been approved by the administration or tech personnel. Using this list without the prior consent of the administration or tech personnel will result in the loss of all computer privileges until further notice. This violation can also contain additional forms of punishment in the form of suspension.**

**2. Privileges** – The use of Internet is a privilege, not a right, and inappropriate use will result in cancellation of those privileges. The Parkston Public School administration will deem what is inappropriate use and its decision is final. The administration, faculty, and staff of Parkston Public School may request the system administrator to deny, revoke, or suspend any specific Internet user's privilege

**3. Netiquette** – You are expected to abide by the generally accepted rules of network etiquette. These include (but not limited to) the following:

- a. Be polite. Do not get abusive in your message to others. Do not send or display offensive Messages or pictures.
- b. Use appropriate language. Do not swear, use vulgarities or any other inappropriate language. Do not harass, insult, or attack others. Illegal activities are strictly forbidden.
- c. Do not reveal your personal address or phone numbers of students or colleagues.
- d. Network storage areas will be treated like school lockers. Network and school administrators may review files and communications to maintain system integrity and insure that users are using the system responsibly. Users should not expect that files stored on district servers will be private. Trespassing on another's folders, work, or files is prohibited and will result in loss of privileges. Messages relating to or support of illegal activities will be reported to the authorities.
- e. Do not use the network in such a way that you would disrupt the use of the network by other users (intentionally wasting limited resources).

- f. All communications and information accessible via the network should be assumed to be private property.

**4. No Warranties** – The Parkston Public School District makes no warranties of any kind, whether expressed or implied, for the service it is providing. The Parkston Public School District will not be responsible for any damages you suffer. This includes loss of data resulting from delays, non-deliveries, or service interruptions caused by its own negligence on your errors or omissions. Use of any information obtained via the internet is at your own risk. The Parkston Public School District specifically denies any responsibility for the accuracy or quality of information obtained through its services. The Parkston Public School District cannot be responsible for inappropriate or offensive material you encounter on the internet. If offensive material would cause you personal embarrassment or other emotional or psychological damage you should not use the system.

**5. Security** – Security on any computer system is a high priority, especially when the system involves many users. If you feel you can identify a security problem on internet, you must notify a system administrator. Do not demonstrate the problem to other users. Do not use another individual’s account without written permission from that individual. Attempts to login to internet as a system administrator will result in cancellation of user privileges. Any user identified as a security risk or having a history or problems with other computer systems may be denied access to the internet.

**6. Vandalism** – Vandalism will result in cancellation of privileges. Vandalism is defined as any malicious attempt to harm or destroy data of another user, internet or any of the above listed agencies or other networks that are connected to the state k-12 email system. This includes, but not limited to, the uploading, creation or intentional transition of computer viruses.

**7. Exception of Terms and Conditions** – All terms and conditions as stated in this document are applicable to the Parkston Public School District. These terms and conditions shall be governed and interpreted in accordance with policies of the Parkston Public School Board, the laws of the state of South Dakota and the United States of America.

### **PERMISSION FORM**

I understand and will abide by the above terms and conditions for internet. I further understand that any violation of the regulations above is unethical and may constitute a criminal offense. Should I commit any violation, my access privileges may be revoked, school disciplinary action may be taken and/or appropriate legal action.

**USER’S FULL NAME (PLEASE PRINT)**\_\_\_\_\_

**USER’S SIGNATURE**\_\_\_\_\_

**DATE**\_\_\_\_\_

**HOME ADDRESS**\_\_\_\_\_

**HOME PHONE**\_\_\_\_\_ **GRADE IN SCHOOL**\_\_\_\_\_

**PARENT OR GUARDIAN** (If the student is under the age of 18, a parent or guardian must also read and sign this agreement)

As the parent or guardian of this student, I have read the terms and conditions for internet access. I understand that this is designated for educational purposes and the Parkston Public School District has taken available precautions to eliminate controversial material. However, I also recognize it is impossible for Parkston Public Schools to restrict access to the network. Further, I accept full responsibility for supervision if and when my child’s use is not in a school setting. I hereby give permission for my child to access the internet and E-Mail and certify that the information contained on this form is correct.

PARENT OR GUARDIAN NAME (Please Print) \_\_\_\_\_

PARENT OR GUARDIAN SIGNATURE \_\_\_\_\_

DATE \_\_\_\_\_

**HANDBOOK FORM**

I have read the student handbook and understand all the rules and regulations. I realize the faculty and administration are here to help me in any way necessary. I will feel free to come to the faculty and/or administration with any problems.

PARENT/GUARDIAN SIGNATURE \_\_\_\_\_

PARENT/GUARDIAN SIGNATURE \_\_\_\_\_

STUDENT SIGNATURE \_\_\_\_\_

DATE \_\_\_\_\_

**THERE ARE A NUMBER OF FORMS THAT NEED TO BE SIGNED. IN THE PACKET THAT YOUR CHILD RECEIVED AT REGISTRATION, ARE THE SHEETS THAT NEED TO BE SIGNED. THESE ARE JUST THE SIGNATURE PAGES THAT NEED TO BE RETURNED. THE REASON WE DO THIS IS SO YOU DO NOT HAVE TO TEAR THE HANDBOOK APART.**